



# भारतीय विज्ञान शिक्षा एवं अनुसंधान संस्थान मोहाली

मानव संसाधन विकास मंत्रालय, भारत सरकार द्वारा स्थापित  
सैक्टर-81, नॉलेज सिटी, प० ओ० मनोली, एस० ए० एस० नगर, मोहाली, पंजाब 140306  
**INDIAN INSTITUTE OF SCIENCE EDUCATION AND RESEARCH MOHALI**  
(Established by Ministry of Human Resource Development, Govt. of India)  
Sector-81, Knowledge city, PO-Manauli, SAS Nagar Mohali-140306, Punjab  
PAN No. - AAAAII781K GSTIN No:- 03AAAAII781K2ZS

• Phone : +91-172-2240086 & 2240121 • Fax : +91-172-2240124, 2240266 • <http://www.iisermohali.ac.in> • Email: [stores@iisermohali.ac.in](mailto:stores@iisermohali.ac.in)

CPPP/Institute Website

IISERM (1310)19/20Pur

Dated: 10<sup>th</sup> January 2020

## **NOTICE INVITING E-TENDER**

Online tenders are invited on behalf of Director, IISER Mohali in **TWO BID SYSTEM** for the **Supply and installation of Lab and Office Furniture for TBI** as per technical specification and details given below and BOQ list from the original manufacturer/supplier at CPPP i. e. <https://eprocure.gov.in/eprocure/app>. Tender documents may please be downloaded from the E-procurement portal website <https://eprocure.gov.in/eprocure/app&> Institute website [www.iisermohali.ac.in](http://www.iisermohali.ac.in).

-sd-  
(Mukesh Kumar)  
Assistant Registrar (P&S)



# भारतीय विज्ञान शिक्षा एवं अनुसंधान संस्थान मोहाली

मानव संसाधन विकास मंत्रालय, भारत सरकार द्वारा स्थापित  
सैक्टर-81, नॉलेज सिटी, पं० ओ० मनोली, एस० ए० एस० नगर, मोहाली, पंजाब 140306  
**INDIAN INSTITUTE OF SCIENCE EDUCATION AND RESEARCH MOHALI**  
(Established by Ministry of Human Resource Development, Govt. of India)  
Sector-81, Knowledge city, PO-Manauli, SAS Nagar Mohali-140306, Punjab  
PAN No. - AAAAII781K GSTIN No:- 03AAAAII781K2ZS

• Phone : +91-172-2240086 & 2240121 • Fax : +91-172-2240124, 2240266 • <http://www.iisermohali.ac.in> • Email: [stores@iisermohali.ac.in](mailto:stores@iisermohali.ac.in)

## E-TENDER NOTICE

Tender Ref.- IISERM(1310)19/20Pur	Dated :- 10 <sup>th</sup> January 2020
-----------------------------------	--

### Critical Date Sections

Sr.	Description	Date	Time
1.	Tender Publishing Date and time	10 <sup>th</sup> January 2020	6:00pm
2.	Tender Document download start Date & Time	10 <sup>th</sup> January 2020	6:00pm
3.	Bid Submission start Date & Time	10 <sup>th</sup> January 2020	6:00pm
4.	Bid Submission End date and Time	30 <sup>th</sup> January 2020	Upto 11:00am
5.	Tender opening Date and Time	31 <sup>st</sup> January 2020	At 11:30am

Online tenders are invited on behalf of Director, IISER Mohali in **TWO BID SYSTEM** {Technical and commercial separately} for the following item(s) from the original manufacturer/supplier at CPPP i.e. <https://eprocure.gov.in/eprocure/app>. Tender documents may please be downloaded from the E-procurement portal website <https://eprocure.gov.in/eprocure/app> & Institute website [www.iisermohali.ac.in](http://www.iisermohali.ac.in). Tender fee in shape of DD/Banker Cheque of Rs 590/- (Non-refundable) and EMD of Rs.10,000/- should be submitted by DD /Banker Cheque/FDR/ Bank Guarantee in favour of the Registrar, IISER Mohali payable at Mohali. However, scanned copy of the both tender fee and EMD should be upload on website along with technical bid part. The hard copy of the same in original to be send to the address mentioned below duly superscribing the supply/work name and reference/ tender ID on the envelope and same must reach before opening the bid and if not received within due date the bid will be rejected summerly.

### **The Original EMD and Tender Fee should be sent to:**

Assistant Registrar (P&S)  
Indian Institute of Science Education and Research Mohali  
Sector-81, Knowledge City, SAS Nagar, Mohali, Punjab,  
India, Pin: 140306

**Non-receipt of original EMD and Tender Fee will lead to rejection of tender.**

**Item Details: -**

Sr.	Description	Qty. (in units)
1.	<b>Wall side work bench</b> of size 1500mm L x 750mm W x 900mm H having granite top and one shutter and drawer (WWB2A, as per drawing enclosed)	<b>03</b>
2.	<b>Wall side work bench</b> of size 1220mm L x 750mm W x 900mm H having granite top and one shutter and drawer .(WWB3, as per drawing enclosed)	<b>12</b>
3.	<b>Sitting table</b> of size 1500mm L x 600mm W x 750mm H with one lockable drawer 75mm height, having white cedar bawarian birch laminated post formed top with hardwood lipping.(STT2)(as per drawing enclosed )	<b>06</b>
4.	<b>Sitting table</b> of size 750mm L x 600mm W x 750mm H with one lockable drawer 75mm height, having white cedar bawarian birch laminated post formed top with hardwood lipping.(STT1)(as per drawing enclosed )	<b>02</b>
5.	<b>Wooden top lab stool</b> having wooden top 12 mm thick ply of size 12” dia with adequate support of size 50x50mm square pipe	<b>22</b>
6.	<b>Visitor chair</b> seat should be made of cushion15 mm thick hot pressed PU moulding. Upholstery with high quality fabric. Back provided with black nylon netting so as to provide comfort to the person's back. Provided with arms. Frame should be made from 25 dia CRC A pipe and should be powder coated thickness 50-60 micron.	<b>14</b>
7.	<b>Steel Almirah:</b> SIZE: Height 1970mms, Width 915mms, Depth 485mms supply of Steel Almirah big size manufactured from CRCA sheet conforming to IS: 513-1994 grade 'D' material. The CRCA sheet of uniform thickness of 22 gauge for the body and shelves, 20 gauge for doors frameduly cut and bend with the help CNC machines The doors should be provided with 4mm thick toughened glass having high quality rubber beading on all four sides and further holding with sheet metal strips. Welding on the front frame of the doors should not be acceptable. The front twin door frame should be in single sheet with built in up and down cut outs of size 790mm x 290 mmfor fitment of toughened glass. The doors are provided with 3 way bolting system. The top and bottom end of the locking rod should be horizontally hook type and to be inserted into the horizontal slot and 3-way lock should be operated by single key. The almirah shall be equipped with four adjustable shelves manufactured from 22 gauge CRCA sheet, thereby making five compartments in thealmirah. The steel shelf shall be capable of carrying a uniformly distributed load of 80 kgms. The almirah shall be provided with three hinges for each door having removable hinge pins The feet height/ground clearance shall be 127 mms approx. All the steel components should be pre-treated for de-greasing, de-rusting and phosphating. After proper pre-treatment, the steel components should be epoxy powder coated and oven baked at temp. Above 200 deg. C to provide scratch resistance surface coating film thickness 45-50 microns.	<b>06</b>
	<b>NOTE:</b> <ol style="list-style-type: none"><li>1. Tenders are called in Two Bid System (Technical Bid should have EMD and technical Catalogue, copies of work executed, copies of the certification and past experience. Price Bid have price bid only. The bids not submitted in the manner as indicated, shall summarily be rejected.)</li><li>2. Samples for Sr. No.3, 5 &amp; 6 to be provided with the bids otherwise the bidder will be technically rejected.</li><li>3. The agency must have at least three certification out of ISO-9001, ISO 14001, ISO-18001, BIFMA certification otherwise, their bids will not be considered as technically suitable.</li></ol>	

	<p>4. For all the items, catalogues with photographs to be provided.</p> <p>5. The agency must have supplied lab furniture in any Govt/State/PSU/ Autonomous body valuing at least Rs.4.00 lakh.</p> <p>6. The quantity can increase or decrease. For ducting, actual quantity to be measured at site after award of work. For increase in quantity, payment shall be made on pro rata basis, while for less quantity, actual measured payment shall be given.</p> <p>7. Furniture to be supplied in Knock down mode, wherever possible.</p> <p>8. <b>Warranty: One year</b></p>	
--	--	--

**NB:-**

- I. The Online bids should be submitted directly by the original manufacturer/supplier, If quotation is submitted/filled by any representative/agent/dealer then they must upload a authority certificate from the principal company.**

### **SUBMISSION OF TENDER**

- I. All bid/ tender documents are to be uploaded online at Central Public Procurement portal i.e. <https://eprocure.gov.in/eprocure/app> only and in the designated cover/ part on the website against tender ID. Tenders/ bids shall be accepted only through online mode and no manual submission of the same shall be entertained except tender fee and EMD. Late tenders will not be accepted.
- II. The online bids shall be opened at the office of the Assistant Registrar (P&S), IISER Mohali, on above given date and time. If the tender opening date happens to be on a holiday or non-working day due to any other valid reason, the tender opening process will be attended on the next working day at same time and place. IISER Mohali will not be responsible for any error like missing of schedule data while downloading by the Bidder.
- III. The bidder shall upload the tender documents duly filled in and stamped by the authorized signatory on each and every page. Tender not submitted/uploaded in the prescribed form and as per the tender terms and conditions shall be liable for rejection.
- IV. The bidder shall upload scanned copy of the PAN Card, GST number duly signed and stamped. **Also bidders applying against ‘MSME/NSIC Certificate’ issued by appropriate Authority, should ensure that the certificate attached is relevant to the area of service/supply. For example, If the tender is for “supply & installation of Desktop” the certificate should be issued for activity/area of “Computer supply and services activities etc” otherwise bid will be REJECTED without notice.**
- V. E-procurement system ensures locking on the scheduled date and time. The system will not accept any bid after the scheduled date and time of submission of bid.

### **INSTRUCTIONS**

1. The Online bids should be submitted directly by the original manufacturer/supplier, If quotation is submitted/filled by any representative/agent/dealer then they must upload a authority certificate from the principal company for quoting the price otherwise such quotation will be rejected.
2. The quantity mentioned in this inquiry is and shall be deemed to be only approximate and will not in any manner be binding on the Institute. Before the deadline for submission of the online bid, IISER Mohali reserves the right to modify the tender document terms and conditions. Such amendment/modification will be notified on website against said tender ID.
3. The rates offered should be FOR Chandigarh/Mohali in case of firms situated outside Chandigarh/Mohali, and free delivery at the Institute premises in case of local firms. Supplier from outside India should mention the Ex-works/FOB/FCA/CIF/CIP price clearly. Conditional tenders will be summarily rejected.

4. In case of Ex-godown terms the amount of packaging forwarding freight etc. should clearly be indicated by percentage or lump sum amount. Institute has policy not to make any advance payments towards any purchase, Letter of credit can be opened if required.
5. THE INSTITUTE IS EXEMPTED FROM CUSTOM DUTY under notification no- TU/V/RG/-CDE(1062)/201 CUSTOM DT.30.08.2016.
6. Tax: This Institute is not exempted from the payment of GST. The current rate (i.e. percentage of GST should be clearly indicated included or excluded) wherever chargeable. Please also provide/upload the copy of PAN card, GST number duly self-attested.
7. Concessional GST is applicable for all the items purchased for Research labs vide Ministry of Finance, notification no. 45/22017 dated 14.11.2017 and 47/2017 dated 14.11.2017.
8. Bidder/s quoting in currency other than **Indian Rupee (INR)** should explicitly mention the currency in which tender quoted wherever applicable in Technical Bid along the tender documents.
9. The delivery period should be specifically stated. Earlier delivery will be preferred.
10. The firms are requested to provide/upload detailed description and specifications together with the detailed drawings, printed leaflets and literature of the article quoted. The name of the manufactures and country of manufacture should also invariably be stated. In the absence of these particulars, the quotation is liable for rejection.
11. Validity of offer: 90 days. The warranty period after satisfactory installation should be mentioned and firm should replace all manufacturing defect parts/ whole item under warranty without any extra cost including clearance, freight, taxes. Security deposit/ Bank Performance Guarantee @ 10 % of the value of supply order as per norms may be sought from the firms.
12. The right to reject all or any of the quotation and to split up the requirements or relax any or all the above conditions without assigning any reason is reserved by the IISER Mohali. For any corrigendum and addendum please be checked the website <https://eprocure.gov.in/eprocure/app> and <http://www.iisermohali.ac.in>
13. Disputes, if any, shall be subject to jurisdiction in the court of Mohali only.

-sd-  
(Mukesh Kumar)  
Assistant Registrar (P&S)

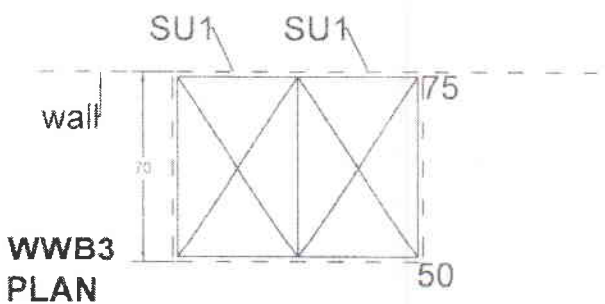
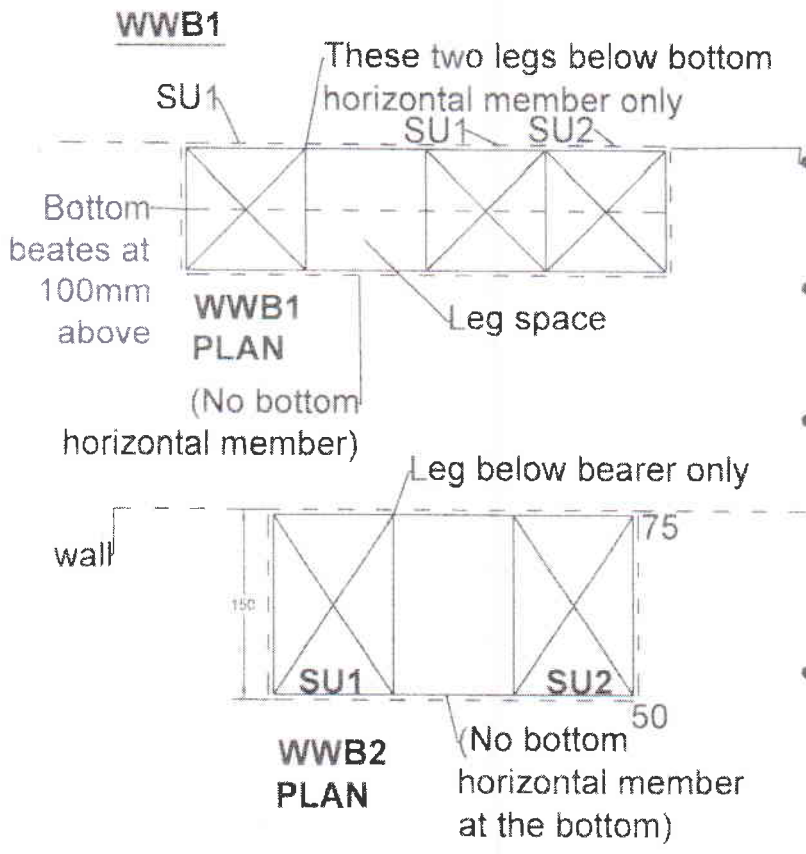

- All work benches 900 and 750mm deep (all work top sides)
  - WWB1; wall work bench 2440(8') long.
  - WWB2; wall work bench 1830(6') long.
  - WWB2 1500 long.
  - WWB3; wall work bench 1220 long.
  - WSU; sink unit against wall 610 long.
- WWB2N; wall work bench  
6'3" high \* 2' wide
- WWB2WD; " "
  - WWB3WD; " "
  - WWB3WD; 4'3" high \* 3' wide

- Granite top projection 75mm at the back (No rounding) with 100 high splashrack of same material
- Other 3 sides projected to be 50mm top edge  $\frac{1}{4}$  rounded and polished
- Note; where 2 unit are formed that side not to be rounded but straight cut and polished
- All storage units should name group rocking system (or all drawers in one vertical row should have one key)

**WALL SINK UNIT**



WSU(ss); Stainless Steel Sink  
WSU(c); Ceramic Sink  
(600 wide, 900 deep, 900 high)

- Expect where mentioned otherwise all tops will be 1st quality plain jet black ceramic polished and rounded/straight cut as below
- see sheet 3 below

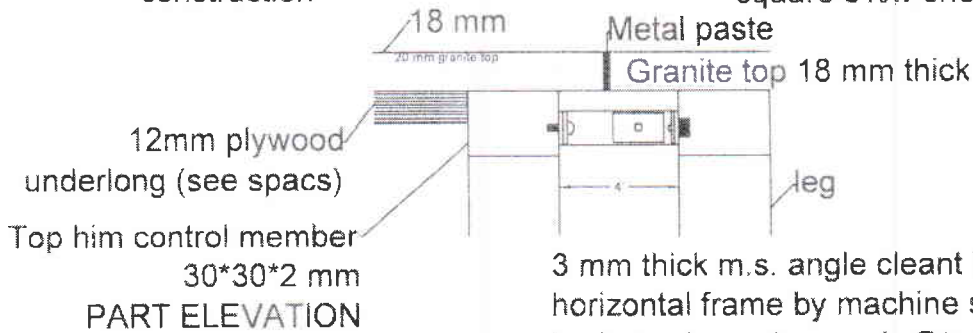
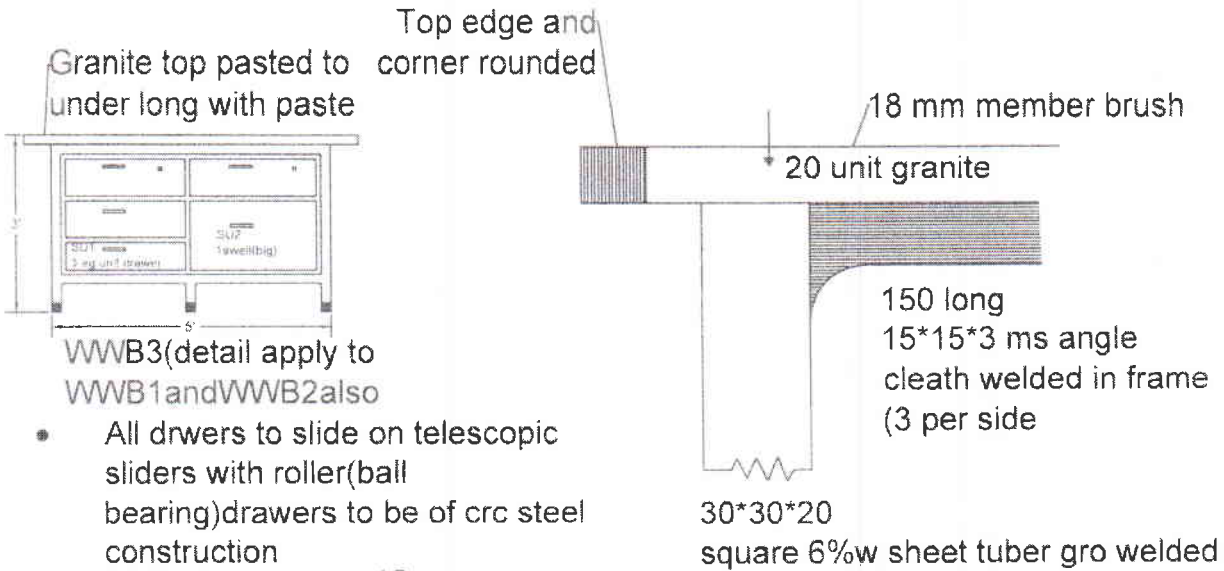

3 mm thick m.s. angle cleant 75\*90\*30 high screwed to the horizontal frame by machine screws in tapped hole&(2 per horizontal member each @top and bottom) locked to the clent from the adjoining table

T Tpical detail for connecting work benches (after installation)

PART PLAN

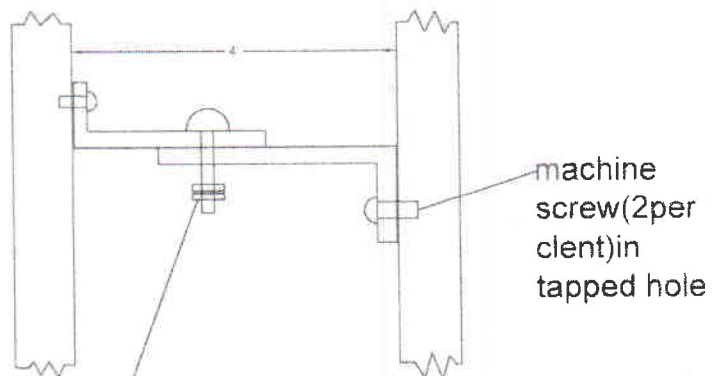

with washer & 2 units(lock nut)



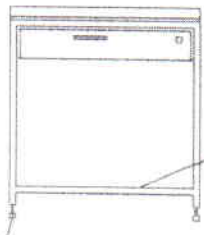

Footrest 200  
inside from front  
leveling screw

STT1 ; student writing table  
750,600,750high(including  
leveling screw)

STT2 ; " " 1500,600,750high

Bearer for slider's

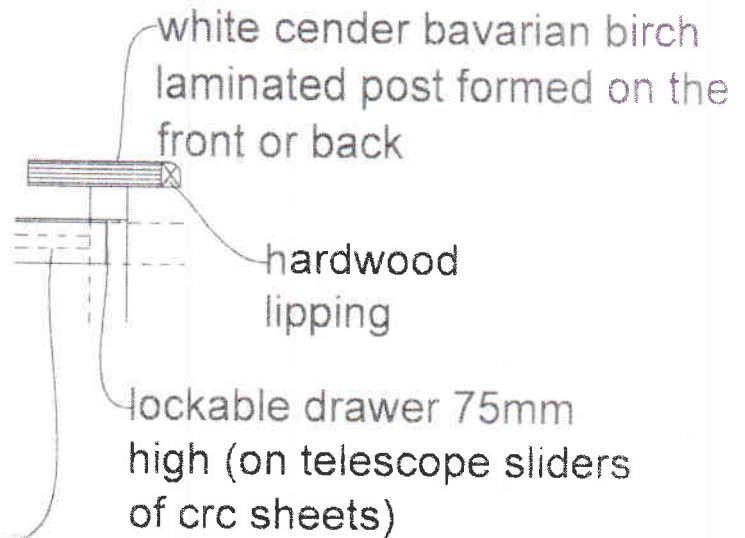

List of additional types tables with some changes based on  
wwb (wall work beanch)on sheats 1 and 2;

WWB1W; wall work beanch 8',2'wide,3'high with

WWB2W; " " 6',2'wide,3'high

WWB3W; " " 4',2'wide,3'high

SSP2 ; special table 6' ,4'wide,2'6"high with white top

SPT3 ; " " 4',4'wide 2'6" high. SPT3

STT1 ; students'writing table 2'6"long, 2'6"wide and  
2'6"high with laminate top(see detail SST1alone)  
and 1drawer 3" high 2'6"(n)

SST2 ; " " 5'long,2'wide,2'6"high with 2  
drawers 2'6" wide(n)3" high STT2

BSU ;big sink unit

ISU ;islant utility shaft