



भारतीय विज्ञान शिक्षा एवं अनुसंधान संस्थान मोहाली

मानव संसाधन विकास मंत्रालय, भारत सरकार द्वारा स्थापित

सैक्टर 81, नॉलेज सिटी, प.ओ. मनोली, एस. ए. एस. नगर, मोहाली, पंजाब 140306

INDIAN INSTITUTE OF SCIENCE EDUCATION AND RESEARCH MOHALI

(Established by Ministry of Human Resource Development, Govt. of India)

Sector-81, Knowledge city, PO-Manauli, SAS Nagar Mohali-140306, Punjab

PAN No. - AAAAI1781K TAN NO. PTLI10692D

• Phone : +91-172-2240086 & 2240121 • Fax : +91-172-2240124, 2240086 • <http://www.iisermohali.ac.in> • Email: stores@iisermohali.ac.in

CPPP/Institute Website

IISERM(921)17/18Pur

Dated- 30th November 2017

E-TENDER NOTICE

Online tenders are invited on behalf of Director, IISER Mohali in **TWO BID SYSTEM** {Technical and Commercial} for the supply & installation of **Fume hoods and lab furniture's** as per technical specification given below alongwith drawing and BOQ list the original manufacturer/supplier at CPPP i.e. <https://eprocure.gov.in/eprocure/app>. Tender documents may please be downloaded from the E-procurement portal website <https://eprocure.gov.in/eprocure/app> & Institute website www.iisermohali.ac.in.

-sd-

(Mukesh Kumar)

Assistant Registrar (S&P)



भारतीय विज्ञान शिक्षा एवं अनुसंधान संस्थान मोहाली

मानव संसाधन विकास मंत्रालय, भारत सरकार द्वारा स्थापित

सैक्टर 81, नॉलेज सिटी, प०ओ० मनोली, एस० ए० एस० नगर, मोहाली, पंजाब 140306

INDIAN INSTITUTE OF SCIENCE EDUCATION AND RESEARCH MOHALI

(Established by Ministry of Human Resource Development, Govt. of India)

Sector-81, Knowledge city, PO-Manauli, SAS Nagar Mohali-140306, Punjab

PAN No. - AAAAI1781K TAN NO. PTLI10692D

• Phone : +91-172-2240086 & 2240121 • Fax : +91-172-2240124, 2240086 • <http://www.iisermohali.ac.in> • Email: stores@iisermohali.ac.in

CPPP/Institute Website

E-TENDER NOTICE

Tender Ref.- IISERM(921)17/18 Pur	Dated :- 30 th November 2017
-----------------------------------	---

Critical Date Sections

Sr.	Description	Date	Time
1.	Tender Publishing Date and time	30 th November 2017	6:00pm
2.	Tender Document download start Date & Time	30 th November 2017	6:00pm
3.	Bid Submission start Date & Time	30 th November 2017	6:00pm
4.	Bid Submission End date and Time	26 th December 2017	Upto 11:00am
5.	Tender opening Date and Time	27 th December 2017	At 11.30 am

Online tenders are invited on behalf of Director, IISER Mohali in **TWO BID SYSTEM** {Technical and Commercial separately} for following item(s) from the original manufacturer/supplier at CPPP i.e. <https://eprocure.gov.in/eprocure/app>. Tender documents may please be downloaded from the E-procurement portal website <https://eprocure.gov.in/eprocure/app> & Institute website www.iisermohali.ac.in. Tender fee in shape of DD/Banker Cheque of Rs 500/- (Non-refundable) and EMD of Rs. 70,000/- should be submitted by DD /Banker Cheque/FDR/ Bank Guarantee in favour of the Registrar, IISER Mohali payable at Mohali. However, scanned copy of the both tender fee and EMD should be upload on website along with technical bid part. The hard copy of the same in original to be send to the address mentioned below duly superscribing the supply/work name and reference/ tender ID on the envelope and same must reach before opening the bid and if not received within due date the bid will be rejected summarily.

The Original EMD and tender fee should be sent to:

Assistant Registrar (S&P)

Indian Institute of Science Education and Research,
Mohali Sector 81, SAS Nagar, Mohali, Punjab, India,
Pin: 140306

Non-receipt of original EMD and tender fee will lead to rejection of tender.

Item Details:-

Sr.	Details of Specifications	Qty.
1.	Fume Hood 1800 mm wide with scrubber and blower all complete as per enclosed specification(each fume hood should have their separate scrubber and blower).	3 nos.
2.	FRP ducting of diameter 200 mm	100 mtr.
3.	Wall side work bench of size 2400mm L x 750mm W x 900mm H having granite top and one shutter and drawer.(WWB1, as per drawing enclosed)	2 Nos
4.	Wall side work bench of size 1830mm L x 750mm W x 900mm H having granite top and one shutter and drawer.(WWB2, as per drawing enclosed)	1 No
5	Wall side work bench of size 1500mm L x 750mm W x 900mm H having granite top and one shutter and drawer.(WWB2A, as per drawing enclosed)	8 nos.
6	Wall side work bench of size 1200mm L x 750mm W x 900mm H having granite top and one shutter and drawer.(WWB3, as per drawing enclosed)	2 Nos
7	Island work bench of size 2400mm L x 1500mm W x 900mm H, having granite top and one shutter and drawer.(IWB1)(as per drawing enclosed)	2 Nos
8	Island work bench of size 2400mm L x 1500mm W x 900mm H, having marble top and one shutter and drawer.(IWB1)(as per drawing enclosed)	1 Nos
9	Island work bench of size 1830mm L x 1500mm W x 900mm H, having granite top and one shutter and drawer.(IWB2)(as per drawing enclosed)	2 Nos
10	Island work bench of size 1200mm L x 1500mm W x 900mm H, having granite top and one shutter and drawer.(IWB4)(as per drawing enclosed)	1 Nos
11	Sitting table of size 1500mm L x 600mm W x 750mm H with one lockable drawer 75mm height, having white cedar bawarian birch laminated post formed top with hardwood lipping.(STT2)(as per drawing enclosed)	2 Nos
12	Sitting table of size 750mm L x 600mm W x 750mm H with one lockable drawer 75mm height, having white cedar bawarian birch laminated post formed top with hardwood lipping.(STT1)(as per drawing enclosed)	9 Nos
13	Wall chemical storage cabinet of size 600x600mm made up of MS powder coated sheet with lockable double leaf (as per drawing enclosed)	45 Nos
14	Wall chemical storage cabinet of size 1800x600mm made up of MS powder coated sheet with lockable double leaf (as per drawing enclosed)	4 nos.
15	Ventilated Chemical Cupboard (VCC) of size 1830x762x2440 mm	2 nos.
16	Island reagent rack (IRR2) of size 1830x300x675 mm	2 Nos
17	Wall side reagent rack (WRR2) of size 1830x300x675 mm	3 Nos
18	Storage unit 2 (SU2) having one small and one big drawer.	15 Nos
19	Granite top table of size 1200x750x900mm with one no of SU2	1 Nos
20	Equipment table with electrical trunking (EQT1) of size 900x900x900mm having granite top	2 Nos

21	Drying shelves above wall sinks of size 600x900mm	2 Nos
22	Big sink unit of size 1500x900x900mm made up of MS powder coated sheet with granite top(BSU, as per drawing enclosed)	1 Nos
23	Wall side sink unit of size 600x750x900mm made up of MS powder coated sheet with granite top(WSU, as per drawing enclosed)	1 Nos
24	Providing and fixing of Tall steel Cabinet of size 6 ft height x 1.5 ft width and 1.5 ft deep with locks made up of 0.8mm thick CRCA sheet body and door frame to be constructed with 1.0mm thick CRCA sheet with powder coating of 50 micron. One shelf at 3 ft dividing each cabinet into two compartments with lock each. Further one more shelf in top compartment is required	1 Nos
<p>Note :</p> <ol style="list-style-type: none"> 1. Samples for Sr. No.5, 12, 13 & 18 to be provided with the bids otherwise the bidder will be technically rejected. 2. The agency must have at least three certification out of ISO-9001, ISO 14001, ISO-18001, BIFMA certification otherwise, their bids will not be considered as technically suitable. 3. For all the items, catalogues with photographs to be provided. 4. The agency must have supplied lab furniture in any Govt/State/PSU/Autonomous body valuing at least Rs.24.00 lakh. 5. The quantity can increase or decrease. For ducting, actual quantity to be measured at site after award of work. For increase in quantity, payment shall be made on pro rata basis, while for less quantity, actual measured payment shall be given. 6. Furniture to be supplied in Knock down mode, wherever possible. 7. Warranty for one year. 		

NB:- The online updated Price BOQ is in INR format. If bidder want to quote other than INR please specify the quoted currency in the technical bid/part and fill the amount in same updated BOQ.

SUBMISSION OF TENDER

- I. All bid/ tender documents are to be uploaded online at Central Public Procurement portal i.e. <https://eprocure.gov.in/eprocure/app> only and in the designated cover/ part on the website against tender ID. Tenders/ bids shall be accepted only through online mode and no manual submission of the same shall be entertained except tender fee and EMD. Late tenders will not be accepted.
- II. The online bids shall be opened at the office of the Assistant Registrar (P&S), IISER Mohali, on above given date and time. If the tender opening date happens to be on a holiday or non-working day due to any other valid reason, the tender opening process will be attended on the next working day at same time and place. IISER Mohali will not be responsible for any error like missing of schedule data while downloading by the Bidder.
- III. The bidder shall upload the tender documents duly filled in and stamped by the authorized signatory on each and every page. Tender not submitted/uploaded in the prescribed form and as per the tender terms and conditions shall be liable for rejection.
- IV. The bidder shall upload scanned copy of the PAN Card, GST number duly signed and stamped.
- V. E-procurement system ensures locking on the scheduled date and time. The system will not accept any bid after the scheduled date and time of submission of bid.

INSTRUCTIONS

1. The Online bids should be submitted directly by the original manufacturer/supplier, If quotation is submitted/filled by any representative/agent/dealer then they must upload a authority certificate from the principal company for quoting the price otherwise such quotation will be rejected.
2. The quantity mentioned in this inquiry is and shall be deemed to be only approximate and will not in any manner be binding on the Institute. Before the deadline for submission of the online bid, IISER Mohali reserves the right to modify the tender document terms and conditions. Such amendment/modification will be notified on website against said tender ID
3. The rates offered should be FOR Chandigarh/Mohali in case of firms situated outside Chandigarh/Mohali, and free delivery at the Institute premises in case of local firms. Supplier from outside India should mention the Ex-works/FOB/FCA/CIF/CIP price clearly. Conditional tenders will be summarily rejected.
4. In case of Ex-godown terms the amount of packaging forwarding freight etc. should clearly be indicated by percentage or lump sum amount. Institute has policy not to make any advance payments towards any purchase, Letter of credit can be opened if required.
5. THE INSTITUTE IS EXEMPTED FROM EXCISE AND CUSTOM DUTY under notification no- 51/96 – CUSTOM DATED 23/7/1996 AND DSIR REGISTRATION NO TU/V/RG/-CDE(1062)/2016 DT. 30/08/2016 / EXCISE NOTIFICATION NO. 10/97- CENTRAL EXCISE DT. 01.03.1997.
6. Tax: This Institute is not exempted from the payment of GST. The current rate (i.e. percentage of Sales Tax should be clearly indicated included or excluded) wherever chargeable. Please also provide/upload the copy of PAN card, GST number duly self-attested.
7. The delivery period should be specifically stated. Earlier delivery will be preferred.
8. The firms are requested to provide/upload detailed description and specifications together with the detailed drawings, printed leaflets and literature of the article quoted. The name of the manufactures and country of manufacture should also invariably be stated. In the absence of these particulars, the quotation is liable for rejection.
9. Validity of offer: 90 days. The warranty period after satisfactory installation should be mentioned and firm should replace all manufacturing defect parts/ whole item under warranty without any extra cost including clearance, freight, taxes. Security deposit/ Bank Performance Guarantee @ 10 % of the value of supply order as per norms may be sought from the firms.
10. The right to reject all or any of the quotation and to split up the requirements or relax any or all the above conditions without assigning any reason is reserved by the IISER Mohali. For any corrigendum and addendum please be checked the website <https://eprocure.gov.in/eprocure/app> and <http://www.iisermohali.ac.in>
11. Disputes, if any, shall be subject to jurisdiction in the court of Mohali only.

-sd/-
(Mukesh Kumar)
Assistant Registrar (S&P)

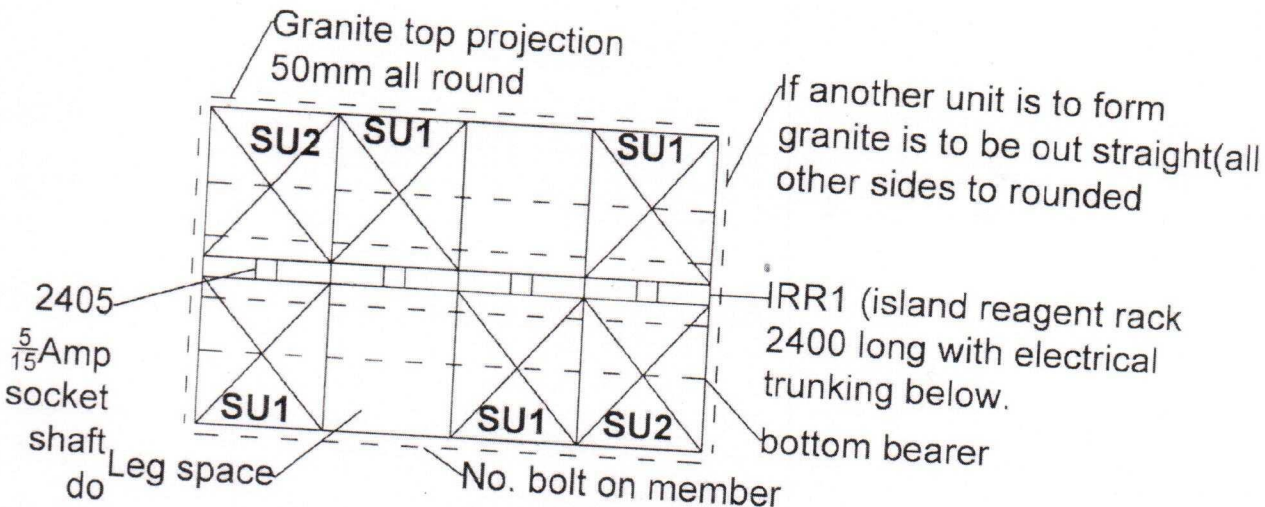

lwb1; island work bench. 2440*1500*900high - Item no - 7 + 8.

facing both sides (16 sockets)

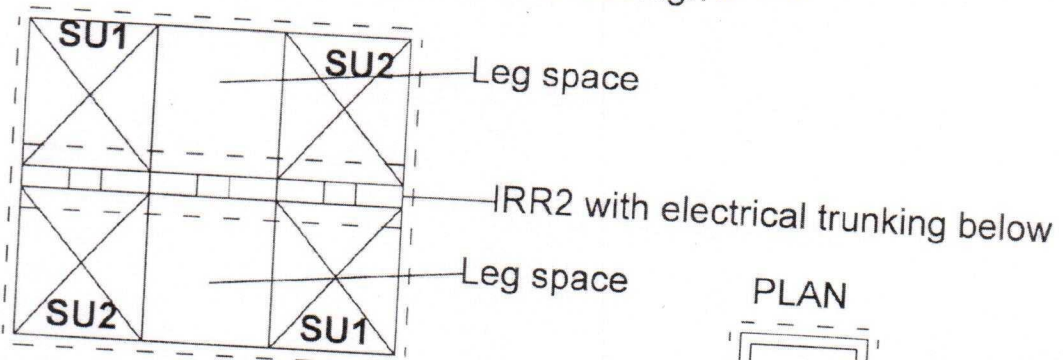

(12 sockets)

Item no 9

lwb2; island work bench. 1800*1500*900high

PLAN

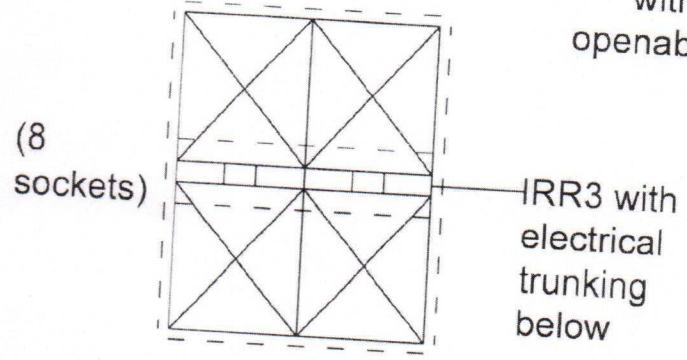

(8 sockets)

These 2 sides with modular openable panels

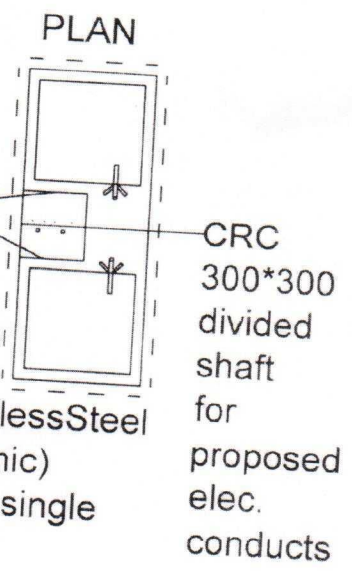

lwb3; island work bench. 1220*1500*900high

PLAN

lwb4; island work bench. 915*1500*900high

Item no 10

All PLANS

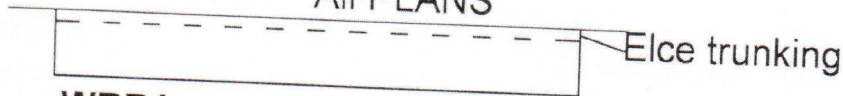

WRR1 wall reagent rack 8'1"2'3"high

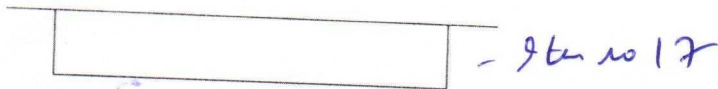

WRR2 wall reagent rack 6'1"2'3"high

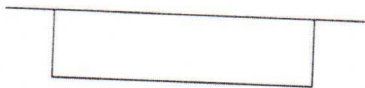

WRR3 wall reagent rack 4'1"2'3"high

Note; All racks formly fixed to wall by chemical resistant (85) screw and suitable normal plugs

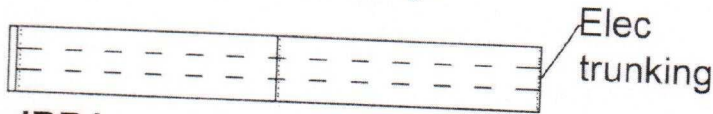

IRR1 Island reagent rack 8'1"2'3"high

Note; All reagent racks to be attached to bench tops without toppling possibility

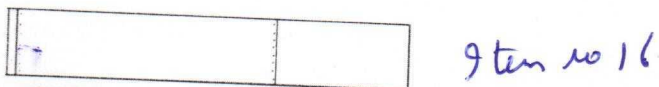

IRR2 Island reagent rack 6'1"2'3"high

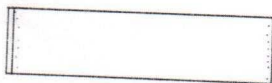

IRR3 Island reagent rack 4'1"2'3"high

IRR4

Note; All reagent racks are to be of crc sheets of adequate strength

- For all these bult on shaft at 4'9" height with electrical trunking below.
- Every 2' space 2ms $\frac{5}{15}$ Amp sockets.
- Top of rack at 7' wt and interimidate shaft at 1'6" ht.

ELECTRICAL

- For all these bolt on shaft at 1'6" above wasle top with electrical end trunking below.
- Every 2' space 2ms $\frac{5}{15}$ Amp sockets, facing both sides.

Top of rack at 5'6" height & intermediate shaft at 4'6"ht

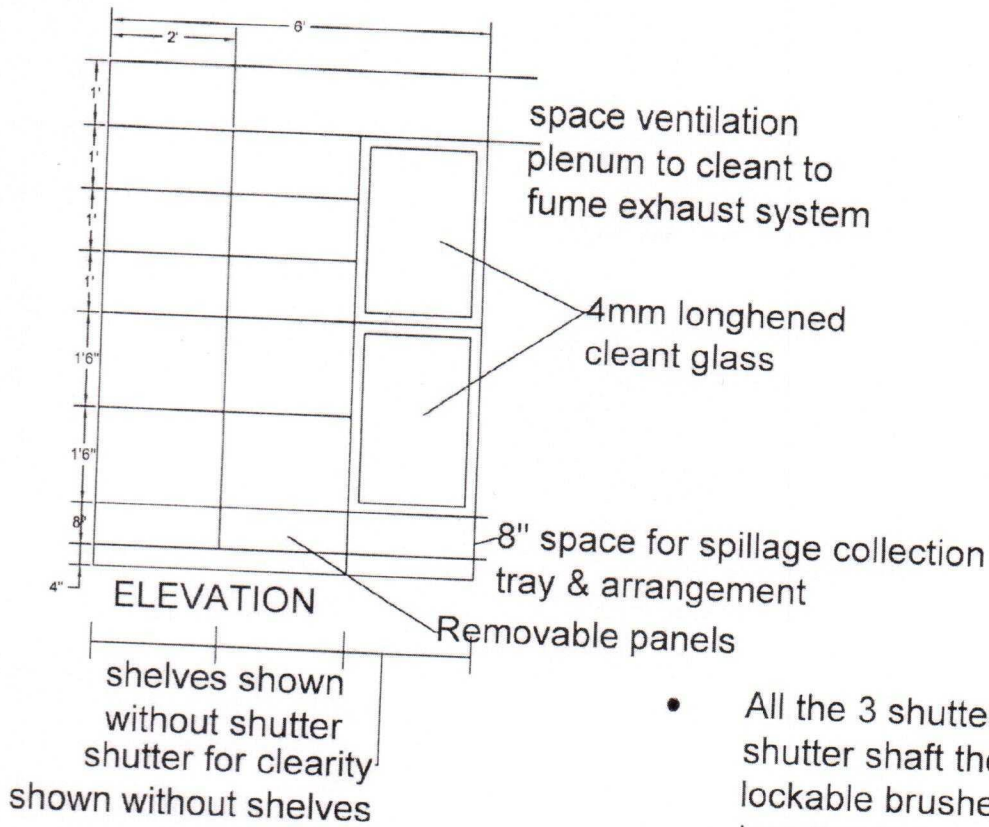

- All the 3 shutter and 3 bottom shutter shaft the individually lockable brushed stainless pull handles to be provided
- leveling bolts/brushes to provided at the bottom

9 Jan no 15 **VCC:** Ventilation chemical copboard (vcc) 2'6" deep
 (To be constructed out of crc sheets with each shelf beaing with adequate stiffenets to take the loading (1 shelves 10 kgs; 1'6" shelves; 20kgs each)

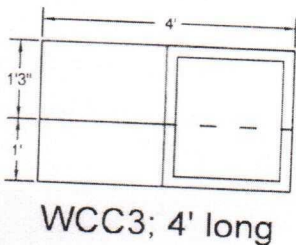
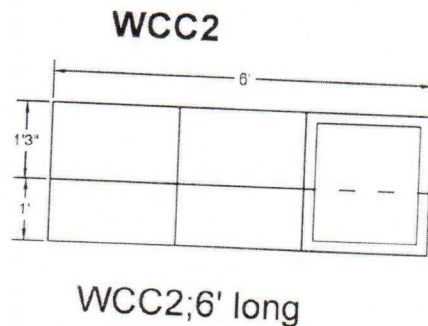
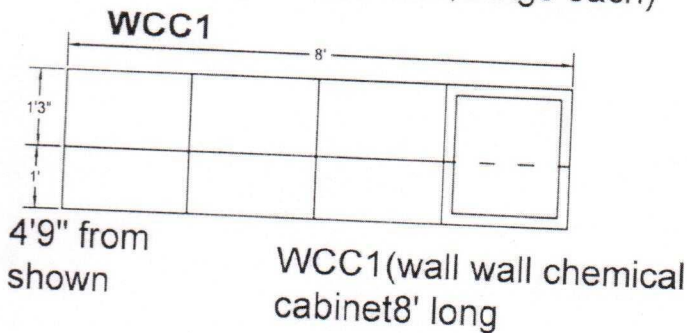

- Only one shutter shown for clerity in each cabinet
- All cabinets 1'3" deep
- Electrical trunking tube provided below all cabinets

2ms 15/5 amp out
lets every 2'

stem no 13814

9 items 3, 4, 5, & 6.

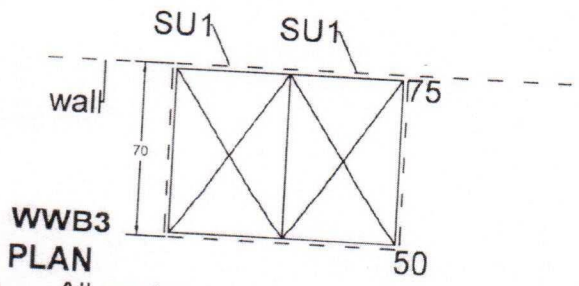
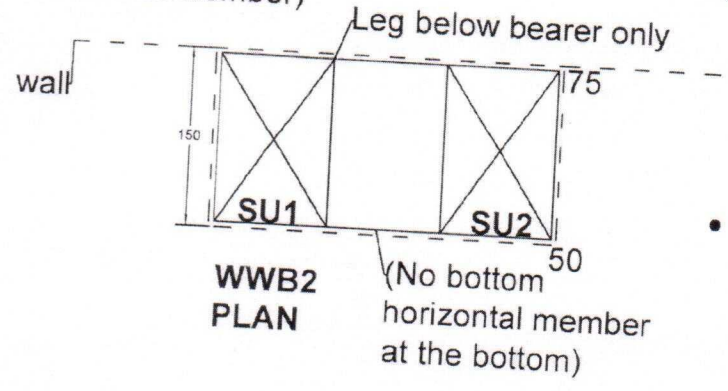
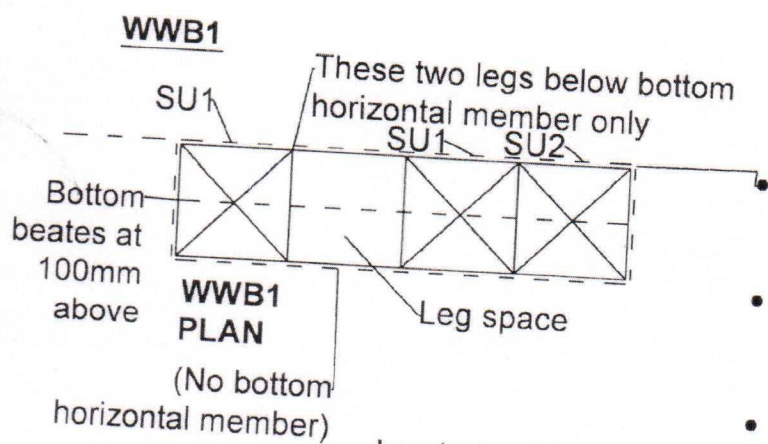

- All work benches 900 and 750mm deep (all work top sides)
 - WWB1; wall work bench 2440(8') long.
 - WWB2; wall work bench 1830(6') long.
 - WWB2 1500 long.
 - WWB3; wall work bench 1220 long.
 - WSU; sink unit against wall 610 long.
- WWB2N; wall work bench
 6'3" high * 2' wide
 • WWB2WD; " " " "
 6'3" high * 3' wide
 • WWB3WD; " " " "
 4'3" high * 3' wide

- Granite top projection 75mm at the back (No rounding) with 100 high splashrack of same material
- Other 3 sides projected to be 50mm top edge $\frac{1}{4}$ rounded and polished
- Note; where 2 unit are formed that side not to be rounded but straight cut and polished

- All storage units should name group rocking system (or all drawers in one vertical now should have one key)

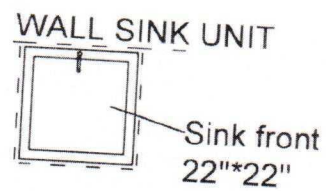

WSU(ss); Stainless Steel Sink
 WSU(c); Ceramic Sink
 (600 wide, 900 deep, 900 high)

- Expect where mentioned otherwise all tops will be 1st quality plain jet black ceramic polished and rounded/straight cut as below
- see sheet 3 below

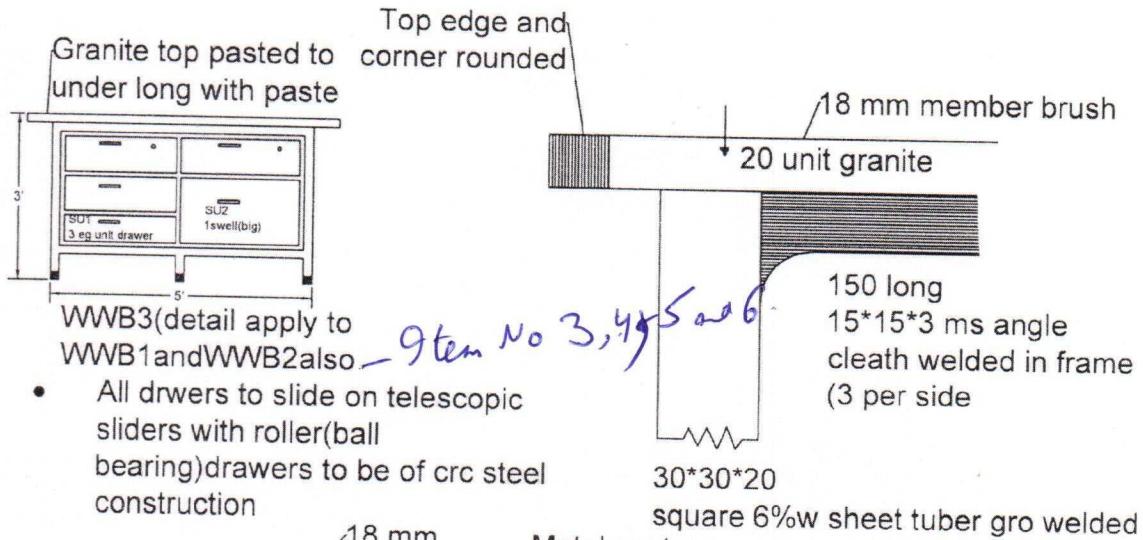

- All drawers to slide on telescopic sliders with roller (ball bearing) drawers to be of crc steel construction

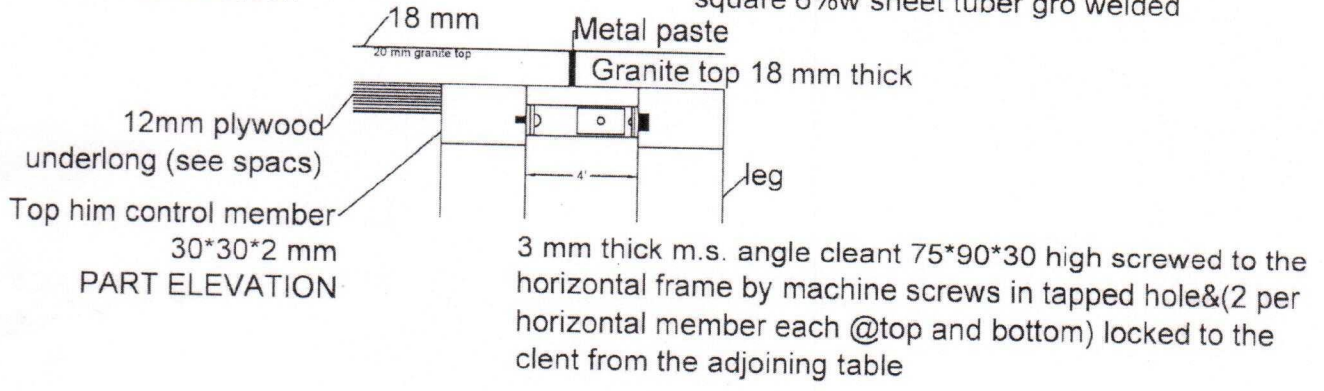

Typical detail for connecting work benches (after installation)

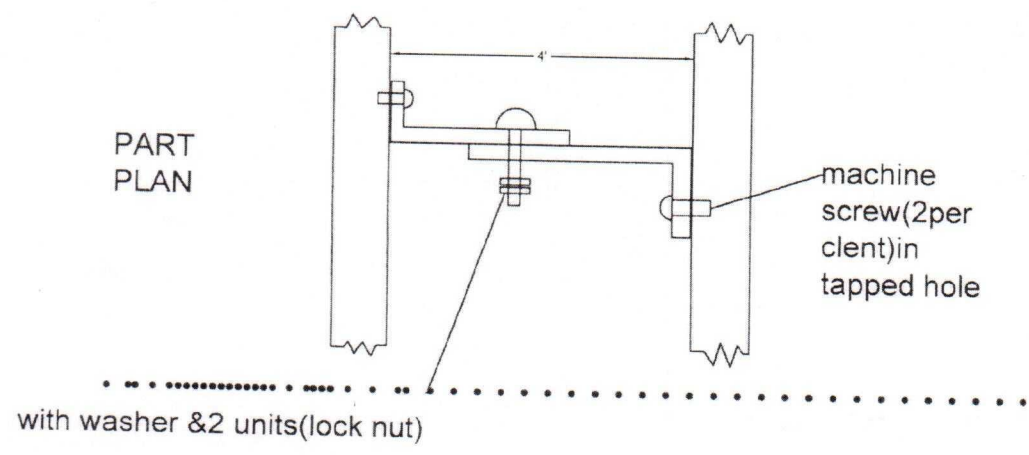

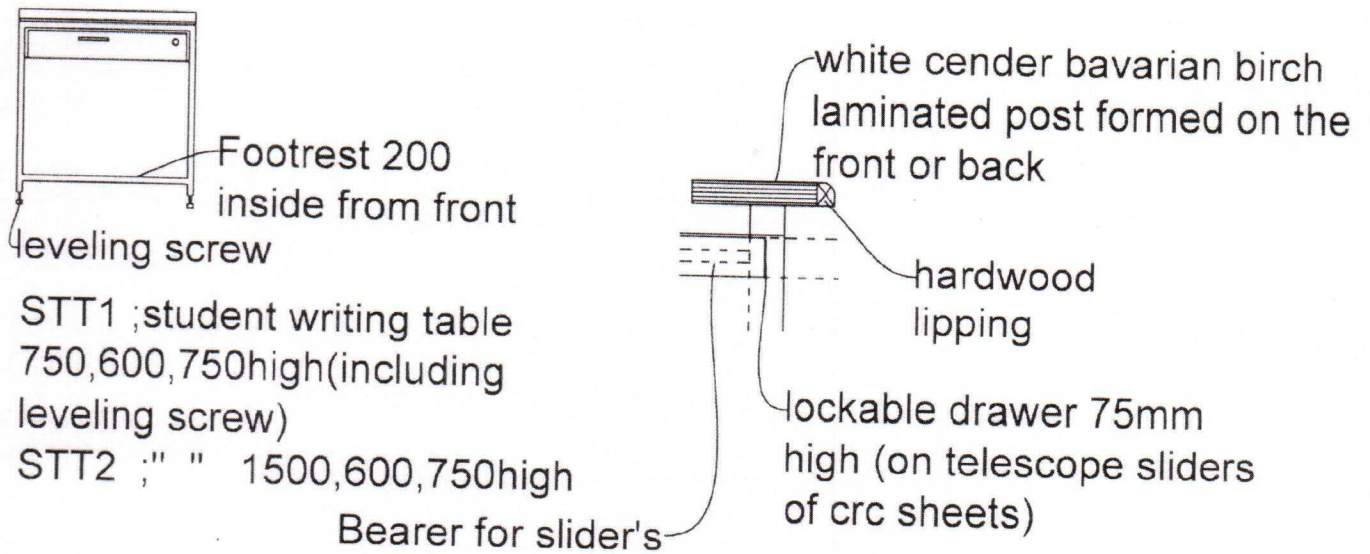

List of additional types tables with some changes based on
wwb (wall work beanch) on sheats 1 and 2;

WWB1W; wall work beanch 8', 2' wide, 3' high with

WWB2W; " " 6', 2' wide, 3' high

WWB3W; " " 4', 2' wide, 3' high

SSP2 ; special table 6', 4' wide, 2'6" high with white top

SPT3 ; " " 4', 4' wide 2'6" high. SPT3

STT1 ; students' writing table 2'6" long, 2'6" wide and *- Item no 12*
2'6" high with laminate top (see detail SST1 alone)
and 1 drawer 3" high 2'6"(n)

SST2 ; " " 5' long, 2' wide, 2'6" high with 2 *- Item No 11*
drawers 2'6" wide(n) 3" high STT2

BSU ; big sink unit

ISU ; islant utility shaft

2.0 FUME HOODS

2.1 Standard Fume Hood Performance Requirements

- Fume hoods shall be of complete KD (Knock down) construction with airfoil design to insure maximum operating efficiency. Foil sections at the front facials of the hood shall minimize ed-dying of air currents at the hood face and the rear baffle system shall minimize turbulence in the upper portion of the hood interior.
- ✓ Test Method – The hood shall be tested by a third party as per the American Society of Heating, Refrigerating and Air Conditioning Engineers (ASHRAE) Standard 110-1995 and EN-14175.

2.2 Quality Assurance

- The laboratory fume hood manufacturer shall provide fume hood work tops and casework all **manufactured & shipped with** proper packing & should take the full responsibility of the entire scope of works as specified in the tender.
- **Each fume hood should come Pre Wired along with PDI (Pre Dispatch Inspection Report)**

2.3 Specifications

- **Superstructure Frame** – A free-standing rigid panel structure of steel (G.I.)
- **Interior Walls-** Double wall ends, not more than 6" wide, shall be provided to maximize interior working area. The area between the double wall ends shall be closed to house the remote control valves. Cutouts to be provided inside the fume hood for service line accessibility. The same to have a cover with a fastener free design. The vertical facias shall contain the required service controls, electrical switches and receptacles.
- **Airfoil** – A streamlined airfoil shall be integral at the bottom of the hood opening on bench and distillation hoods. This foil shall provide a nominal 20mm open space between the foil and the top front edge of the work surface to direct an air stream across the work surface to prevent back flow of air. The sash to be provided with a separate handle which also provides for air flow when in completely closed position. The foil shall be 1.2mm steel to resist denting and flexing.
- **Baffle-** A stable, non-adjustable baffle with a single slot on the back baffle to aid in distributing the flow of air into and through the hood. The baffle shall be space out from the back liner and shall be removable for cleaning.
- **Duct Collar-** A 8"-10" diameter polyethylene funnel shaped rectangular duct collar shall be located in the top of the hood plenum chamber.
- **Lighting-** Two fluorescent light fixture (inclusive of CFL tubes) of 20 volts each to be provided in the fume hood. The lighting fixture to be completely outside the fume hood area.
- **Sash-** A sash provided should be move in a vertical rising steel frame without any noise. The bottom of the sash frame shall have a full length metal handle. The ash track has minimum protrusion to avoid any kind of turbulence. The sash shall be counterbalanced with a weights to prevent tilting and binding during operation. The glass panels shall be 5mm toughened glass mounted in an leveled channel with roller for smooth operation.
- **Plumbing Services** – Utility services like Nitrogen, Vacuum, Compressed Air & Potable water shall consist of remote control valves as selected located within the end panels, controlled by in and out facility with flexible hose passing through the side panels of the hood, with color coded plastic handles. Interior fitting for water shall be with powder coated brass. All gas valves for regular lab gases to have standard needle valve and push and turn type arrangement for all

burning gases to be supplied. All supplied valves to clear the following pressures test conditions: Gas Fittings- 7 bar, Water fittings-10 bar.

- **Electrical Services** – The hood superstructure shall be fully wired and should have a control box with MCB blower starter all safety devices like trip etc. Inlet to be of 3 phase power supply and the whole electrical to be of plug and play type. It also has 4 nos. electrical sockets and switches of Northwest make (230 V, 5/16 A, 50 Hz)
- **Liner-** Interior liner panels shall be 6 mm thick Phenol resin base industrial laminate.
- **Digital Panel-** Fume hoods shall be provided with an alarm system to detect low and high hood face velocities. The alarm system shall indicate the actual face velocity of sash position. The system have an air velocity sensor mounted on the interior side liner of the hood where it is easily accessible for cleaning. The velocity monitor shall have a digital display of the air velocity through the hood face in feet per minute. The alarm signals shall activate any time the face velocity falls below the low velocity alarm set point or rises above the high velocity alarm set point. There shall be both visual and audible alarm signals. The audible alarm shall have a mute. Low and high alarm contacts shall be provided for remote monitoring.
- **Lattice Rod Assembles** – 12mm diameter solid SS rods shall be completed with the PP clamps to form a lattice arrangement to hold the test samples and rotors within the fume hood.
- **Centrifugal Blower-** Silent high efficiency remote blower consisting of continuous rating motor and chemical resistant impellar. The blower is designed to give a face velocity at safe working height as per the international safe velocity norms. (ANSI/AIHA Z9.5). The blower body is polypropylene UV treated, high density and chemical (corrosion) resistant and is mounted on a metallic stand.
- **Ducting** – Rigid Ducting of PP (Polypropylene) + FRP (Fibre Reinforced Polyester) and flexible ducting with flanges, bends, damper transitions, clamps etc. Flexible joint is provided in the ducting in order to avoid transmitting the blower vibrations to the hood. A weather proof rain cowl is provided at the outlet of blower.

• **Scrubbers Specifications:**

General details			
	For 1 no. LCV fume hoods of 6 feet width	For 2 nos. LCV fume hoods of 6 feet width each	For 3 nos. LCV fume hoods of 6 feet width each
Capacity	1000 CFM for two 6 feet width LCV fume hoods	2000 CFM for two 6 feet width LCV fume hoods	3000 CFM for three 6 feet width LCV fume hoods
Working temp.	Ambient	Ambient	Ambient
Design temp.	60 degree celcius	60 degree celcius	60 degree celcius
Type	Vertical Packed Bed scrubber with circulation tank and recirculation pipes and fittings.	Vertical Packed Bed scrubber with circulation tank and recirculation pipes and fittings.	Vertical Packed Bed scrubber with circulation tank and recirculation pipes and fittings.
Motor(MAKE-		1 HP, 2980 RPM,	1.5 HP, 2980 RPM,

KIRLOSKAR/ AMBICA/	0.5 HP, 2900 RPM, Capacity 50 ltr/min, Head 5 mtrs	Capacity 50 ltr/min, Head 5 mtrs	Capacity 50 ltr/min, Head 5 mtrs
KRANTI			
	Material for Construction		
Bottom/room/ shell	PP + FRP	PP + FRP	PP + FRP
Manway necks/Reinf. Pads	PP + FRP	PP + FRP	PP + FRP
Manway flanges	PP + FRP	PP + FRP	PP + FRP
Nozzle necks	PP + FRP	PP + FRP	PP + FRP
Nozzle flanges	PP + FRP	PP + FRP	PP + FRP
Gasket	Natural resin – 3mm	Natural resin – 3mm	Natural resin – 3mm
Bolts and nuts	GI	GI	GI
	Thickness		
Tank	3 mm PP + 5 mm FRP	3 mm PP + 5 mm FRP	3 mm PP + 5 mm FRP
Scrubber	3 mm PP + 3 mm FRP	3 mm PP + 3 mm FRP	3 mm PP + 3 mm FRP
	Painting		
Outside of tank	Smoke grey	Smoke grey	Smoke grey
Inside of tank	NIL	NIL	NIL

***Other**

Accessories like overflow provision and water level indicator.

Less space occupation, maximum efficiency and maximum recollection. All nozzles shall be provided with FRP gussets.

Water fill shall be done to take care of leakage. Floor space requirement of 2 m X 2m.

Water fill test shall be done to take care of leakage

- **Base Cabinets** – Fume hoods are designed to rest on a bench (high base stand, pedestal or a cabinet) which is a complete rigid steel structure. Gauge of steel used in its construction shall be 0.8 mm GI.
- **Transition-** Used to connect fume hood with ducting should be designed to reduce the static pressure and is made up of PP-FRP.
- **Work Surface** – Hood work surface shall be 20mm thick jet black granite made in the form of a watertight pan, not less than 7 mm deep to contain spillage. Worktop will have oval 100mm x 200mm 'PP' Cup-Sink for drainage. The work surface and cup drain shall be available in black colour.

3. PERFORMANCE REQUIREMENTS

3.1 **Steel Casework Construction Performance**

- Base cabinets shall be constructed to support at least a uniformly distributed load of 250 kgs.
- Each leg should have a load capacity of 450 kg
- Each adjustable and fixed shelf support an evenly distributed load of 40 Kg.
- All drawers shall operate smoothly, a minimum of 1,00,000 cycles with an evenly distributed load of 25 kg.
- Swinging doors on floor-mounted casework shall support 45+45 Kg. suspended at a point 1 feet from hinged side, with doors swung through an arc of 90 degrees. Weight load test shall allow only a temporary deflection, without permanent distortion or twist. Door shall operate freely after test and assume a flat plan in a closed position.

The steel surface to follow the following testing standards

S.No.	Characteristic	Specifications	Method Used
1	DFT (DRY FILM) THICKNESS	35 micron	ELCOMETER OR DFT METER
2	GLOSS AT 60 DEGREE	70+units -	GLOSS METER
3	SCRATCH	3Kgs	SCRATCH HARDNESS TESTER
4	IMPACT RESISTANCE	275 Kg.cm	IMPACT TESTER
5	CROSS CUT ADHESION	1X1 mm or GT	
6	FLEXIBILITY	3.25 mm	CYLINDERICAL MANDREL BENDING TESTERS

7	ERICHSEN CUPPING	8 mm	ERICHSEN CUPPING TESTER
8	SLAT SPRAY	1000 hours	SALT SPRAY CHAMBER

Zinc Phosphate deposition rate: 1.1 gm/mt. Square, IS – 3618 (1966) Reaffirmed in 1991 and IS - 6005 (1998).

Mild Steel (CRC): IS-513 (1994) Reaffirmed in 1998.

3.2 Service Fittings and Accessories

- **Laboratory Service Fittings:** Service fittings shall be laboratory grade, and water faucets and valve bodies shall be cast red brass alloy or bronze forgings. All fittings shall be powder plated unless specified otherwise.
- **Service Indexes:** Fittings shall be identified with service indexes in the colour coding as per DIN 12920.
- All water faucets and gas valves should meet the following performance tests and requirements.

3.2.1 **Chemical Resistance:** Finish shall meet the following tests for chemical resistance:

3.2.2 **Fume Test :** Suspended coated sample in a container at least 6 cubic foot capacity, approximately 12" above open beakers, each containing 100 cc of 70% nitric acid, 94% sulfuric acid and 35% hydrochloric acid respectively. After exposure to these fumes for 150 hours, the finish on the samples shall no discoloration, disintegration or other defetcs

3.2.3 **Direct Application Test:** Subject coated samples to the direct action of the reagents and solvents listed below at a temperature of 25 degree C dropping from a burette at the rate of 60 drops per minute for ten minutes. Finish on the samples shall not rupture, though slight discoloration or temporary softening is permissible.

3.2.4 **Mar and Abrasion Resistance:** Finishes shall a have pencil hardness of 2H-4H with adhesion substantial enough to withstand both direct and reverse impacts of 160 inch pounds. Finish shall have excellent mar resistance and be capable of withstanding scuffing, marring and other ordinary wear.

3.2.5 **Reparability:** Finish shall b capable of surface repair in the event that a fitting is scratched or a surface rupture occurs. The service fitting manufacturer shall have available an air-drying coating, specially formulated to match the existing finish colour, which may be applied in the field to repair coated surfaces.

4.1 Dampers and Flexible Hose

4.1.1 **General –** Volume control damper sets shall be provided where specified according to the specifications in the offer BOQ. Dampers shall be double thickness heavier than the thickness of the large duct & shall be rigid in construction. The volume control dampers shall be of an approved type, lever operated & complete with locking devices which will permit the dampers to be adjusted & locked in any positions. Construct blades of 3 mm thick PP MOC, provide heavy-duty molded self-lubricating nylon bearings, 13mm (1/2") diameter Plastic axles spaced on 225 mm

(9") centers. Construct frame of 300 mm diameter outer with Flange for fitting minimum 6 bolts and nuts. The outer shell body shall be transparent material of Poly propylene. Automatic \$ manual volume opposed blade shall be not over 225mm wide. The dampers for fresh air inlet shall additionally provide with fly mesh screen, on the outside of 0.8 mm thickness with fines mesh.

- 4.1.2 Manually Adjustable Damper Sets – Damper sets shall be arranged in substantial supporting frames and each blade shall be mounted on a shaft, which turns in sintered bronze bearings. All damper blades shall be inter-connected by means of a suitable bar linkage for ganged operation. All dampers shall be arranged with spindle horizontal and shall be sized to handle the air quantities shown on the drawings. Where manually adjustable damper sets are installed in duct work or other accessible locations the operating shafts shall be extended through the duct and a lockable quadrant fitted.
- 4.1.3 Bird Screens – Galvanized woven mesh or weld mesh bird screens in rigid galvanized iron frames shall be installed behind all Bypass exhaust air openings to the outside of the building.
- 4.1.4 Flexible Connections – Provide flexible duct connections wherever duct work connects to vibration isolated equipment and on all exhaust final connections to spot extractor and as indicated on the drawings. Construct flexible connections of neoprene-coated flameproof fabric crimped into duct flanges for attachment to duct and equipment. Make air-tight joint. Provide adequate joint flexibility to allow for thermal, axial, transverse and tensional movement and also capable of absorbing vibrations of connected equipment. Flexible connections shall be air tight and resistant to water and fire. Flexible connections shall be fitted to isolate fans from equipments and/or duct work. The connections shall be arranged to permit the renewal of the connection without distributing the duct work or the plant. The metal parts of connected equipment shall be separated by not less than six inches and installed with sufficient slack to compensate for free movement of fans or spring vibration isolators.