



भारतीय विज्ञान शिक्षा एवं अनुसंधान संस्थान मोहाली
मानव संसाधन विकास मंत्रालय, भारत सरकार द्वारा स्थापित
सैक्टर 81, नॉलेज सिटी, पं० ओ० मनोली, एस० एं एस० नगर, मोहाली, पंजाब 140306
INDIAN INSTITUTE OF SCIENCE EDUCATION AND RESEARCH MOHALI

(Established by Ministry of Human Resource Development, Govt. of India)
Sector-81, Knowledge city, PO-Manauli, SAS Nagar Mohali-140306, Punjab
PAN No. - AAAAI1781K

• Phone : +91-172-2240086 & 2240121 • Fax : +91-172-2240124, 2240266 • <http://www.iisermohali.ac.in> • Email: stores@iisermohali.ac.in

IISERM (874)17/18Pur.

19th December 2017

Corrigendum-II

Refer IISER Mohali E-tender Ref. no. IISERM (874)17/18 Pur for **Supply of Gas Distribution System for EHEP lab** at IISER Mohali, Sector-81, Knowledge City, PO-Manauli, SAS Nagar Mohali, Punjab. Due date for the online submission is extended as per below schedule.

A) Revised Date and Time

Sr.no.	Description	Extended Due date/Time
01	Closing Date & Time (Online)	04/01/2018 up to 11:00 AM
02	Opening Date & Time of Technical Bid	05/01/2018 at 11:30 AM

B) Pre- Bid meeting Clarifications/Amendments/modification in the Technical Specifications are mentioned below.

For any information, other modifications and/or corrigendum may kindly visit IISER Mohali websites <http://www.iisermohali.ac.in> & <https://eprocure.gov.in/eprocure/app>

Sd/-
Mukesh Kumar
Assistant Registrar (S&P)

Clarifications to GAS Distribution System For EHEP Lab in AB2

As per the requests and queries received during pre-bidding, we provide clarifications and additional information through this document. Bidder must comply all our conditions and specs as per this document as well as all other documents along with our original NIT document. Please check carefully all the sections (Annexure – 1, Annexure – 2 and Answers) for more detailed explanations wherever it is applicable. No further clarifications will be entertained.

- 1. Technical evaluation shall be made strictly based on the original terms and conditions of NIQ as well as this document.*
- 2. The replies to the questions during pre-bidding will also form the part of NIQ.*
- 3. If any vendor still desires to see the site, they are free to do so.*
- 4. Once the technical bids are opened, no clarification will be given to any vendor.*
- 5. List of mandatory Documents to be submitted in following order:*
 - A. Technical Bidding Document that includes: (i) compliance chart for specs, (ii) list of components including makes, model number and specifications (Not simply copy of manuals and brochures rather a compiled document), (iii) Detailed P&ID drawings for proposed solutions and (iv) Detailed P&ID drawing for individual type of panels and gas cabinets etc.*
 - B. OEM Certificates and documents (also D.1), stating explicitly that they are qualify to handle high purity solutions for toxic, corrosive and flammable gases.*
 - C. Vendor may submit any other documents like other required documents (completion certificates of previous works, references and any other documents that mentioned in NIT and current documents etc.), manuals and specifications, feature lists and brochures etc.*

A.2	<p>Additional Clarification - Detail of Gases:</p> <ul style="list-style-type: none"> • “Xenon” is corrected in the list. • Added expected flow rates of individual gases in the annexure – 2. • The purity of gases is clarified in annexure – 2. • Please check annexure – 1 and annexure – 2 for more detail. • See Annexure – 1 for more explanations of Compressed Air Line and Generated Nitrogen Line
	<p>Additional Clarification - Seamless tubing - (Electro Polished):</p>

A.3	<ol style="list-style-type: none"> 1. Clarification about Extra lines are given in annexure – 1 2. Additional specs are provided in annexure - 1 <p><i>Qualified Brands: Dockweiler, Valex, Cardinal, Sandvik</i></p>
A.4	<p>Additional Clarification - Primary pressure control Regulator Panel:</p> <ol style="list-style-type: none"> 1. All gas lines must have appropriate regulator capable of delivering 0 to 5 bar absolute pressures. 2. We require multi-valve gas panel system for flammable/toxic/corrosive gases inside the cabinets with emergency shut-off & 3-way Purge block. Thus, the panels must have at least: <ul style="list-style-type: none"> ○ Three valves as integral part of purge block (one cylinder isolation diaphragm valve - pneumatically operated, one purge gas inlet diaphragm valve and one waste gas outlet diaphragm valve), ○ One leak test diaphragm valve ○ One downstream process outlet diaphragm valve ○ One downstream process vent diaphragm valve ○ Purge gas check valve. ○ Panel must have all above number or more of valves integrated into it 3. We require multi-valve gas panel system for all other gases except flammable/toxic/corrosive gases. Thus, the panels must have at least: <ul style="list-style-type: none"> ○ One high pressure process valves ○ One leak test diaphragm valve ○ One downstream process outlet diaphragm valve ○ One downstream process vent diaphragm valve ○ Purge gas check valve. ○ Panel must have all above number or more of valves integrated into it 4. Vendor must provide proper P&ID diagram for each panel system with valves positioning and operations specifications. 5. Vendor must provide the complete flow diagram and P&ID diagram for each type of gas lines. 6. Panel with all above valves system (minimum of above 7 types or 5 types of valves system) must have a provision for future conversion into fully automatic panel system. Venders must provide <i>a separate breakdown in quotation</i> as an upgrade option for the conversion of asked panel into fully automatics panel control. Price bid is accordingly modified. 7. Check annexures for additional information. <p><i>Qualified Brands for OEM assembled panels and regulators: AES, Spectron, Air Liquide, Praxair, Tescom, Aptech</i></p>
A.5	<p>Additional Clarification - Valves, clamps, diaphragm and related accessories:</p> <ol style="list-style-type: none"> 1. Filter at the process gas inlet valve: Diaphragm-type shut-off valves optimized for low flow <p><i>Qualified Brands for Diaphragm Type Isolation Valves: Aptech, Cajon, Spectron, Swaglok, Hamlet</i> <i>Qualified Brands for Tube Clamps: Hilti, Stauff, unistruct, swaglok</i> <i>Qualified Brands for Electro Pneumatic Actuated Valve: Swagelok, Parker, Spectron, Asco, Aptech</i></p>
A.6	<p>Additional Clarification - Mass Flow Controller (MFCs): 5 Pcs</p> <ol style="list-style-type: none"> 1. Please check Annexure – 1

	<p>2. Price bid is modified accordingly.</p> <p>Qualified Brand: Fujikin, Bronkhrst, MKS, Brooks, Horiba, Alicat</p>
A.7	<p>Additional Clarification - Gas cabinet and housing of cylinder:</p> <ol style="list-style-type: none"> 1. Gas cylinders stored outside cabinet should have wall-mounted brackets with chain to restrain them. 2. Water sprinkler should be installed inside flammable cabinet and integrated to fire system. <p><i>Qualified brand: Spectron, AES, Air Liquide, Asecos, Praxair</i></p>
A.8	<p>Additional Clarification - Gas Monitoring and alarm System:</p> <ol style="list-style-type: none"> 1. Additional details are provided in annexure – 1 <p><i>Qualified Vendor: Honeywell, Bionics, Draeger</i></p>
A.9	<p>Additional Clarification - Personal Protective Equipment (PPE) and Accessories should be provided by vendor</p> <ol style="list-style-type: none"> 1. Mask with Compatible Cartridge for the Gases mentioned in the table 2. Full Bodysuit: two full bodysuits with integrated cartridges. 3. Nitrogen Gun: Two-nitrogen gun, oil-free polypropylene or PTFE type. 4. Mobile Gas leak detector: Specified in sensors
B.1	<p>Additional Clarification - NITROGEN Generator:</p> <ol style="list-style-type: none"> 1. A nitrogen generator capable of 5N or better nitrogen at 5 LPM or better should be installed along with an oil free compressor. An oil free nitrogen booster (must not degrade the purity 5N) to store nitrogen for 6-11 bar pressure in cylinder 2. Provide a 500 L Nitrogen storage tank made out of SS-304 or SS-316. 3. Usage 20L/minutes 4. Price bid is modified accordingly. <p><i>Qualified Brands for Nitrogen generator: Mathesoan gas, Parker, Peak Scientific</i></p>
B.2	<p>Additional Clarification - Air Compressor:</p> <ol style="list-style-type: none"> 1. 500 Liters storage tank to be able to host gases at 8-11 bar or more pressure. 2. Compressor must have inbuilt/external dryer to achieve -20DGC PDP or less. 3. Productions 50L/minutes or more; must have a dryer with pressure dew point -20C 4. Usage 20L/minutes 5. Price bid is modified accordingly. <p><i>Qualified Brands for Air Compressor: Ingersoll Rand, Kaeser, Atlascapco, Junair</i></p>
C.1	<p>Additional Clarification - Gas Cylinders:</p> <ol style="list-style-type: none"> 1. See Annexure – 2 for more detail. 2. Price bid is modified accordingly. <p><i>Qualified Vendors: Linde, Praxair, Mathesongas, Inox Air products, Messer, Air Liquide</i></p>

Annexure - 1: IISERM (874) 17/18Pur

This document is meant to clarify our original tender document; all other terms & conditions will remain same.

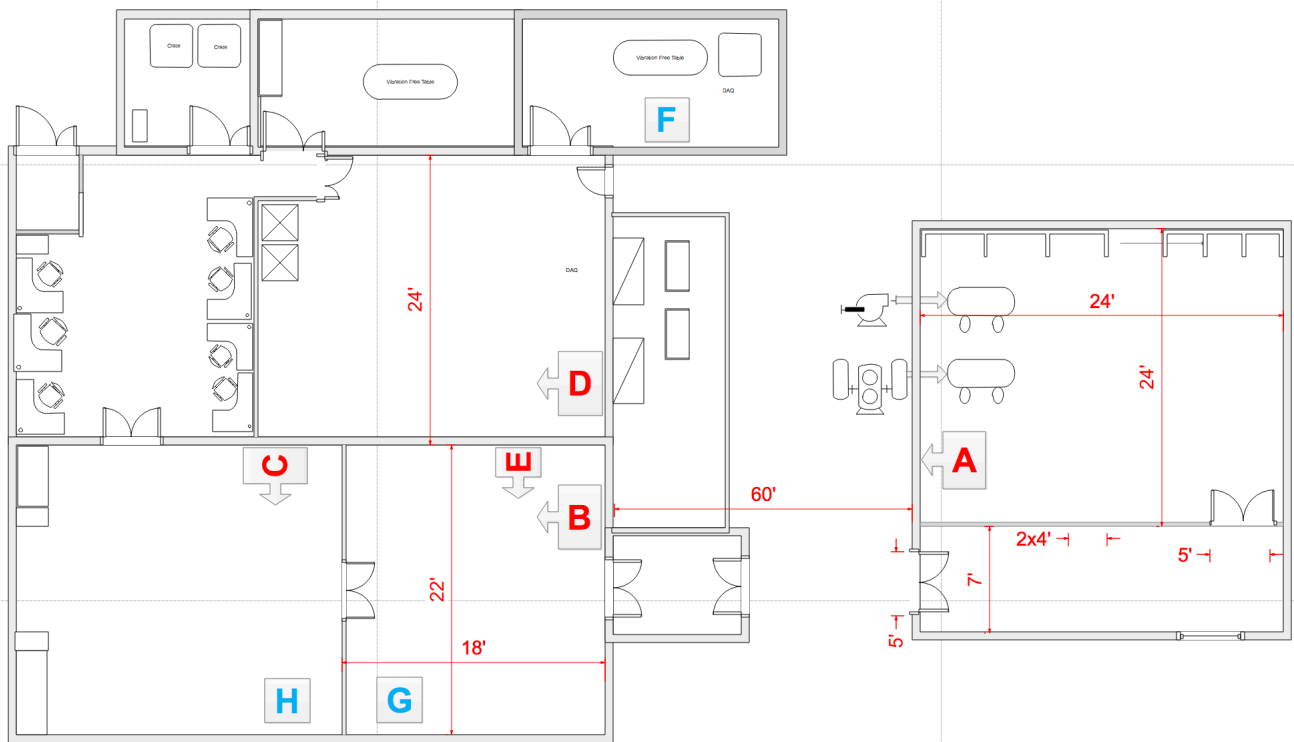

Black Lines are Gas Service Lines
Red Lines are Generated N2
Blue Lines are Compressed Air

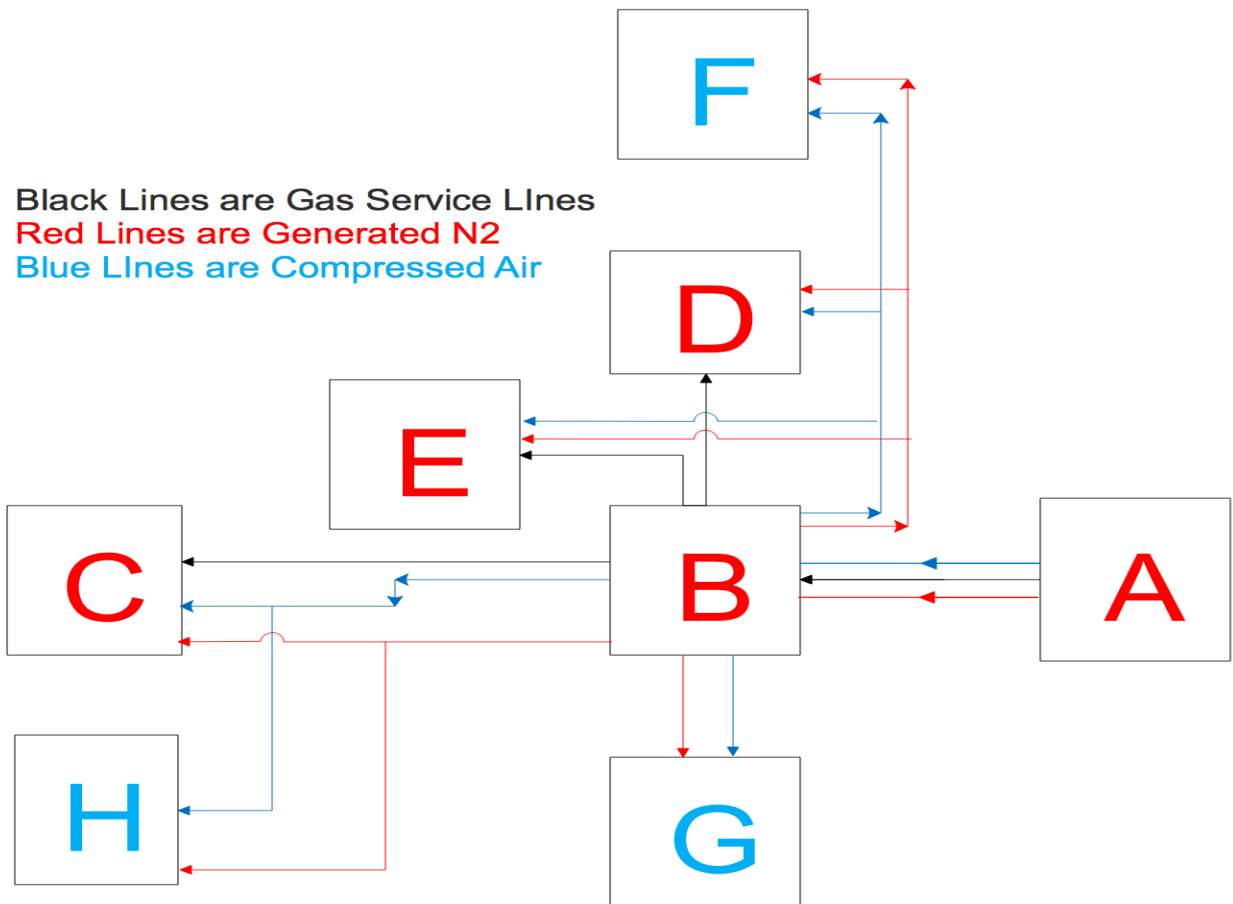

Sln	Detail Explanation and clarifications
1	<p>Layout and Schematics lab and gas bank:</p> <ol style="list-style-type: none"> 1. Top figures: shows the schematics and position representation of actual layout of buildings and utility areas. Although the dimensions are given in the schematics, vendors must take final measurement before installations. 2. Bottom Figure: Topological layout of different areas as shown in top figure to illustrate the connections and to lay the gas-service lines 3. The temperature at every utility points and areas including gas bank will be maintain at 22-24C throughout the year. 4. Bidder/Vender must organize cylinders as per requirements in the gas bank area. 5. Vendor must submit a proper layout/design and work plan during the bidding (3D-Flow diagram is preferable, but not mandatory)
2	<p>Point of Use:</p> <ol style="list-style-type: none"> 1. A: Gas Enclosure, ~60' away from the <i>Point-B</i> 2. B: Location of Control and Distribution Panel 3. C: Utility Area - 1 4. D: Cleanroom Utility Area 5. E: Utility Area - 2 6. F, G, H: Drop lines for Generated Nitrogen (GN) and Compressed Air (CA).
3	<p>Points-A:</p> <ol style="list-style-type: none"> 1. All gas cylinders will be kept in this area (Gas Bank) and pipelines must be routed through <i>Point-A</i> to connect <i>Point-B</i>. 2. Between <i>Point-A</i> to Utility Area <i>Point-B</i>, a rack with over-head shading will be provided. It is the responsibility of vendor to provide appropriate protective insulations to prevent gas lines from outside ambient disturbances like temperature, humidity and pressure. 3. Vendor must group gases in terms of oxidizing gas, toxic gases and flammable gas lines and must put a divided between these gas lines.
4	<p>Point-B:</p> <ol style="list-style-type: none"> 1. This is the point where Gas distribution panel and control system must be mounted on a SS wall mounting structure either anchored to ground or to available wall. 2. Distance between <i>Point-A</i> to <i>Point-B</i> is around 60' 3. All gas line must have pressure gauges installed at this point (including in blank lines, CA and GN).
5	<p>Point-E:</p> <ol style="list-style-type: none"> 1. This point is ~3' from <i>point-B</i>, a SS panel should be put anchored to the ground, which will be used as another point of use (utility area - 2) 2. All gas outlets G01-to-G18, GN, CA, and E-E5 should be made available at this point, where equipment will be connected. 3. Flammable, toxic and corrosive gas outlets should be kept inside respective VMBs and a diaphragm valve should be connected at the end, all other gases lines should be terminated using ball-valve endpoints
6	<p>Point-C:</p> <ol style="list-style-type: none"> 1. First Point of use (point of use – 1), which is ~22' from point-B and it is a non-cleanroom area. 2. Gases to be used: (Check Annexure-2 for coding convention): Ar, CO2, CF4,

	<p>C4H10, Xe, N2, (G03, G, G13, G09, G11, G12, G14), E3, E4, GN, and CA</p> <ol style="list-style-type: none"> 3. All these gas lines should be terminated with valves (flammable gases with diaphragm type valve, and rests gases with ball valves) 4. Flammable gas outlet should be kept inside respective VMBs 5. Vendor should ensure to install a dedicated SS structure to host VMBs and panels, as <i>Point-C</i> doesn't have any solid wall.
6	<p>Point-D:</p> <ol style="list-style-type: none"> 1. Point of use (Inside cleanroom), which is ~8' from point-B. 2. Gases to be used: (Check Annexure-2 for coding convention): Ar, N2, CH4, CO2, C2H2F4, SF6, C4H10 (G03, G08, G13, G09, G11, G12, G14) E1, E2, GN, and CA 3. All these gas lines should be terminated with valves (flammable gases with diaphragm type valve, and rests gases with ball valves) 4. Flammable gas outlet should be kept inside respective VMBs 5. Vendor should ensure to install a dedicated SS structure to host VMBs and panels as <i>Point-D</i> doesn't have and solid wall.
7	<p>Point-F, G, H:</p> <ol style="list-style-type: none"> 1. CA and GN lines should be routed until these points and provide a set of drop points at each point with a valve at each end point. 2. There are six drop points for both CA and GN lines. More clarification of A.2 of NIT: CA line must have a common central regulator and six regulators for six drop points; Similarly, GN line must have a common central regulator and six regulators for six drop points. 3. Point-G is ~30' from Point-B 4. Point-H is ~17' from Point-C 5. Point-H is ~30' from Point-B
8	<p>General:</p> <ol style="list-style-type: none"> 1. All gases are listed in Annexure-2, Vendors must be calculated appropriate numbers of valves, joints, connector, manifolds etc. as per gases, using above requirements to evaluate BOQs and to prepare P & IDs. 2. All end-points should be temporality shielded by a dummy pluck 3. Exhausts of VMBs should be connected back to respective gas cabinets, and exhaust should be done through respective common outlets after leak detection.
8	<p>Scrubber:</p> <ol style="list-style-type: none"> 1. Cl2 scrubbing must be done with KOH in appropriate container integrating with venting and exhausts (Cl2 exhausts line from cabinets + exhausts line for processed Cl2). 2. It must be install outside the building.
9	<p>Extra Lines:</p> <ol style="list-style-type: none"> 1. There will be five extra lines of ¼"; 2. Three extra lines (E1, E2 and E3) for high purity gas CF4 or similar type of gases + 2 lines (E4 and E5) co-axial for CL2 or equivalent corrosive/toxic/flammable type of gases. 3. Extra lines should be routed until empty cylinder stand at Area-A (gas bunker) and nitrogen (GS08) should be temporarily connected to these lines. 4. These lines must have pressure gauges installed at <i>Point-B</i>. 5. These lines should be routed up to <i>Point-E</i> and terminated with respective valves with dummy pluck

10	<p>MFC Types (A.6):</p> <ol style="list-style-type: none"> 1. MFCs should be multi-gas type, with dual (both analog and digital) interface 2. The calibration should be done at site depending on the choice of gas 3. A PLC based control units should be provided to interface MFCs and further to computer via Ethernet connectivity 4. Acceptable accuracy ~0.5 – 1% 5. Connection should be ¼” swage-lock type 6. MFC1: Inert Gases 7. MFC2: Flammable Gases as per Annexure - 2 8. MFC3: SF6, O2 or equivalent gases 9. MFC4: N2, CO2 or for equivalent gases 10. MFC5: CF4, C2H2F4, C3H2F4 or for equivalent gases 11. Addition to all these, vendor must comply the original NIT document 12. Price bid document is modified accordingly
11	<p>Tube dimensions:</p> <ol style="list-style-type: none"> 1. All gas service lines must of diameter ¼”. 2. The gas line for CA and GN must be of ½” or 1”. 3. There will be five extra lines of ¼”. 4. Exhaust pipes must be of 2” diameter or more of compatible materials. 5. There must be three independent exhaust lines for mixed (processed) gases to be exhausted from <i>Point-C</i>, <i>Point-D</i>, and <i>Point-E</i> respectively. 6. Vendor must install separate exhaust lines by grouping oxidizing gases and toxic gases respectively from VMBs to gas cabinets and then to vents.
12	<p>Sensors: (A.8)</p> <ol style="list-style-type: none"> 1. Smoke detector and sensors: 5 (2 in Area A, 1 in Area B, 1 in Area C, 1 in Area D) should be installed and must be integrated to HMI through PLC interface 2. O2 level monitor; 5 (2 in Area A, 1 in Area B, 1 in Area C, 1 in Area D) should be installed and must be integrated to HMI through PLC interface 3. H2 sensors – 3 (one in gas cabinet, one in area B and one in Area C) 4. Sensors for Cl2 – 2 (one at gas cabinet and other in area B) 5. Sensors for SF6 – 5 (2 in Area A, 1 in Area B, 1 in Area C, 1 in Area D) 6. Sensors for all above flammable gases - 5 (2 in Area A, 1 in Area B, 1 in Area C, 1 in Area D) 7. Mobile gas leak detector – 2 (Multi gas type; should be capable to offline data logging, there should be charging unit) 8. All gas sensor must have at least 3 years of warranty 9. All sensors are preferred to have factory/onsite calibration. 10. Sensors must be compatible with Power over Ethernet (PoE) communication interface devices. 11. Ethernet connectivity should be available to commutate and control 12. All sensors must connect to PLC controller for easy integration with HMI systems as well as computer via Ethernet. 13. Central control system must have logging capabilities 14. There must be protective unit like password protected system or biometric system to keep system integrity. 15. Solid-state (with clean fire agent) fire extinguisher, ~2 litre in size, must be provided: 4(2 in Gas Bank, 1 in Area B, 1 in area C)

Annexure-2: Gas Cylinders

Clarification of Purity, Flow-rate, capacity and number of cylinders for each gases

#	IUPAC	Name	Purity	Water capacity In litre	Flow rate (~scch)	Qty
G01	He	Helium	99.999	40	0-300	1
G02	Ne	Neon	99.99	50	0-300	1
G03	Ar	Argon	99.9999	40	0-200 sccm	2
G04	Kr	Krypton	99.999	10	0-100	1
G05	Cl ₂	Chlorine	99.999	10	0-200	1
G06	Xe	Xenon	99.99	10	0-100	1
G07	O ₂	Oxygen	99.999	50	0-200	1
G08	N ₂	Nitrogen	99.9999	50	0-200 sccm	4
G09	CO ₂	Carbon Dioxide	99.999	47	0-300	1
G10	CF ₄	Tetrafluoromethane	99.999	50	0-300	1
G11	C ₂ H ₂ F ₄	TetraFluoroEthane (R134A)	99.999	45	0-300	1
G12	SF ₆	Sulfur Hexafluride	99.999	50	0-50	1
G13	CH ₄	Methane	99.999	45	0-300	1
G14	C ₄ H ₁₀	Iso-butane	99.999	45	0-300	1
G15	C ₃ H ₂ F ₄	TetraFluoropropene (HFO-1234ze)	99.999	45	0-300	1
G16	C ₃ H ₂ F ₄	TetraFluoropropene (HFO-1234yf)	99.999	45	0-300	1
G17	H ₂	Hydrogen	99.999	47	0-300	1
G18	C ₂ H ₆	Ethane	99.999	45	0-300	1
	GN	Generated Nitrogen	See Section B.1 of NIT and Clarification			
	CA	Compressed Air	See Section B.2 of NIT and Clarification			
	E1-E5	Five extra pipelines without regulator panels (see annexure – 1, 9)				

Note:

1. *scch*: Standard Cubic Centimeter per hour; *sccm*: Standard Cubic Centimeter per minute;
2. Vendor should provide separate quotations for each cylinder with the sized mentioned above (or nearest available capacity) gases. We choose the gases to purchase as per our requirements. The price-bid document is modified accordingly.
3. The volume of cylinders is mentioned as per water equivalent in above table. Vendor must evaluate nearest commercially available cylinders and provided the rate for the gas content in terms of Kg, m³ along with a filling pressure in unit of bar. The evaluation will be done using per unit to have uniform comparison.
4. Vendor must provide the “CGA” fitting size for all quoted gas cylinders; it is a mandatory condition for evaluation.
5. Final decision will be taken by technical committee to decide on which cylinder(s) to purchase.
6. Considering the request in delay in purchase & deliver procedure of gas cylinders, the maximum supply time may be 25 weeks.

Answers to Pre-bid meeting

General Comment - 1: All vendors and bidders must understand that, this is not a semiconductor development lab or fab facility. It is a very specialized detector lab, where the flow rate is very low & precise as well as being an academic setup; the mode of operation is very different. Thus, any justification that applies to specialized semiconductor fab or lab may not be always relevant. Therefore, all vendors and bidders must comply with our specifications and as per our requirements. Interested party may provide a copy of respective standard they are referring to, this will be used to compare the compatibility of our requirements.

General Comment – 2: There are several requests to include other makes and brands. We have already added multiple vendors in respective sections, which is enough to have competition and upon requests we have added most suggested brand in respective sections, however bidder must have OEM certificates from brands stating they are trained partners for installing toxic, flammable and corrosive gas handling -systems. Along with the conditions mentioned in our original document, bidders must also agree and satisfy following conditions:

1. Bidder must ensure that the item of their proposed brand fulfill our specs and requirements. No change to our minimum requirement will be acceptable.
2. OEM certificates for brands must be included along with bid documents.
3. Bidder must provide the references of installations in any IITs, IISERs or Govt. National Labs, or Govt. PSU; we may collect information from the mentioned references to crosscheck their claim and we reserve the right to visit installations for qualifying the vender.
4. Detail completion certificates of similar works done at any of the IITs, IISERs, Govt. National Labs or Govt. PSU using bidder’s proposed brands must be provided along with the bidding documents.
5. Detail technical specifications for used brand (other than the manual and direct spec-list from company) must be compiled and provided along with bidding.
6. Bidder must agree that all components supplied in this tender shouldn’t be obsolescence for minimum 10 years. In case of any obsolete the same shall be upgraded or changed at bidder cost at any time within 10 years.
7. Bidder must agree all conditions along with the conditions mentioned in Section-D of NIT Document.

Sln	NIT	Questions	Answers
1	All gases (He, Ne, Ar, Kr), O ₂ , N ₂ , Co ₂ , Cf ₄ , C ₂ H ₂ F ₄ , Sf ₆ , CH ₄ , C ₄ H ₁₀ , C ₃ H ₂ F ₄ , H ₂ , C ₂ H ₆ , CL ₂ .	Makes of Gases specified, Can we offer the other makes of Gases which are approved in Semiconductors Co and also has reference in India also, All Qualifications PO can be submitted	You have not suggested any brand that you represent to include. We have added other brands see general comment-2 Follow tender specifications and annexures

2	Purity should be at least 99.999% or better ultra -pure research grade gas.	Content of gases can be specified by customers, in Kgs and M3, Optional in 47 or 10 Ltrs will also have content issue	Vendor may quote in total weight in Kg and must comply with the tender document for volume. Comparison will be done as per unit weight for the evaluation.
3	5 Spare copies of piping should be laid down up to the distribution panel in utility area for future extension of some gases. Tentative length of each line will be somewhere between 40-50 feet, but will be astimated properly on basis of the location of gas housing cage.(schemtic attached).	For Extra Lines we need know the gas so we can design and offer	Type of extra lines are mentioned in annexure-1
4	Propose schematic of gas flow lines are given with tentative dimensions.	Is site visit is allowed	On prior appointment via stores at least 2 days before tender submission due date/time.
5	All gas lines must be anchored to a tray hooked to the roof.	Confirmation of the same has to be done only after site visit and safety of piping due to some toxic gases	Site is spacious enough to host it
6	Nitrogen and compressed air gas lines should be of 1.0-inch diameter.	We need to know the pressure and flow for N2 gas	Pressure 8-11 bar; Flow rate 20L/m; Follow tender specification
7	Should be electro polished and bidder should agree to the condition that the leak test trial should be approved by end-user before installation.	We need to know the RA of the tube requirements	Comply our specs; Min. 10Ra
	X-ray verification for all joints should be done and report should be provided.	Considering the Gases and Application Request you to go ahead with SEMICONDUCTOR STANDARDS as Per testing Needs	Comply our requirement Note: please see General Comment - 1:
	The tubing supplied shall have the same heat number for the same size.	Traceable Certificates needed for the same	Comply our condition; Note: see General Comment - 1:
	All gases must have SS pipes with orbital-welded joints. All joints must be leak tested	Qualified Welders and Approved to weld such joints with certification worked for	Comply our condition; Note: see General Comment - 1:

	for $\sim 10^{-9}$ mbar l/s or better.	semi fabs companies	
	All gas lines must be purged with N2 to remove particulates.	As per these need we should ask for semiconductor Testings Standards S2 comply	Comply our condition; Note: see General Comment - 1:
	All flammable gases along with H2 must have coaxial lines filled with nitrogen in the outer jacket.	Request for co-axial pressure switch with vacuum method.with VCR Connections	No vacuum, N2 must be purged back to cabinet for detection; Note: see General Comment - 1:
	All toxic and corrosive gases must have co-axial lines flowing with nitrogen (through respective gas cabinet close to the gas sensors) in the outer jacket.	Please let us know the Source of N2 gases is it tank or PSA plant, Volume of Gas will be higher in usage	Source shall be from N2 Generator stored in 500ltrs tank.
	Qualified Brands: Dockweiler, Valex, Cardinal	Request for more Global Brands in Market since its Global Tender and which qualifies Semiconductor Standards for such Gases, Ex - Masco, Ihsungtech, Kinglai	Must Comply our requirement and see general comments – 2 Follow tender specification
	All gas lines must have appropriate regulator capable of delivering 3-5 bar absolute pressure and must be connected via a manual purge plus changeover system.	There should be range of Output since only specific company is designed to deliver such , Please consider global makes with proper range of products Ex - GasArc, Rotarex, Agem, Aptech , TKF, Drastar	This is our requirement, thus everyone must comply it. We can't change our requirement just to satisfy a particular brand or product.
	The control panel should be of the type of wall-and cabinet-mounting pressure control panles;	Specification should be as per Semi Standards or else local makes and fabricated can be supplied.	Please comply our specs. see General Comment - 1:
	Control panels should be of Ergonomically designed for non-corrosive gases up to quality 6.0; Modular design (to be extended to 2,3 etc. cylinders).	Request for VCR panels for CORT and flammable gases as this is as per International semi2 standard.	VCR needed only for Cl2. see General Comment - 1:
	All process gases should come with single cylinder along with primary pressure control panel with NPT/compression ends.	Request for VCR panels for CORT and flammable gases as this is as per International semi2 standard.	VCR for Cl2 only; see General Comment - 1:

	All manifold to be factory tested for 1×10^{-8} mbar l/s of He.	Helium Leak Testing and VCR Connections is needed	Must be of the order of 10^{-9} mBar l/s.
	All manifold should be degreased as per the relevant industrial standard to ensure particle free component.	Particle Count testing from 3rd party as per Semi 2 standards.	Not mandatory; see General Comment - 1:
	The primary pressure control regulator panel should be with 3-way purge block for SF6, Cl2 and other toxic flammable gases (for neutral and noble gases self purging should be provided). A cross purge block arrangement to flush the gas in a small connection volume in pigtail with Nitrogen as propellant gas. The flushed gases must go through the vent line to a safe vent location.	Recommended to use International Standard S2 panel with Vacuum generator, which ensure safety of the user while cylinder changeover and these gas cabinet should be per Semi2 standard with 3rd party certificate to avoid local and substandard vendors.	Venturi required for Cl2, SF6, and flammable gases including H2 with purge block arrangement. Must evacuate the small volume on cylinder connection and not the pigtail.
	Qualified Brands for regulator: AES, Spectron, Air Liquide,	Since global tender, very specific makes are allowed, Additional other makes as per international standards which are used in Semiconductors Fabs or R&D to be approved examples - AccuDevice, Agem, Ishungtech, Drastar Norcimbus, Ceres etc.	See general-comment – 2 Follow tender specification
	Filter at the pressure gas inlet valve: Diaphragm-types shut-off valves optimized for low internal volume with On/Off position indicator.	For which gases do specify the same	All gases
	Should be off pack-less below/diaphragm type rated for at least 250 psi.	For which gases do specify the same	All gases
	Should be provide with 316L stainless steel bodies and downstream of seat with NPT/compression fittings.	VCR is recommended for all such gases	Must comply leak test requirements
	Outlet adapter with integrated relief valve and optional diaphragm-shut-off valve: A	For which gases do specify the same	All gasses other than Cl2

	mechanism should be place to prevent the outlet piping from draining while disconnecting the panel.		
	Must provide auto shut-off for all gases except Nitrogen if any alarm in triggered.	For which gases do specify the same	All gases except N2
	Qualified Brands for Diaphragm Type isolation vales: cajon, spectron, swaglock, hamlet	Since global tender , very specific makes are allowed , Additional other makes as per international standards which are used in Semiconductors Fabs or R&D to be approved examples - TKF, ISHUNG,- KOREA, KINGLAI, APTECH. DKLOK etc.	Follow tender specification; See general-comment – 2
	Qualified Brands for Tube Clamp: Hilti, stauff, unistruct, swaglok	Additional of new vendors required since it's a Products which long durability	Follow tender specification; See general-comment – 2
	Qualified Brands for Electro pneumatic Actuated valve: Swagelok, Parker, Spectron, asco	Since global tender , very specific makes are allowed , Additional other makes as per international standards which are used in Semiconductors Fabs or R&D to be approved examples - TKF, ISHUNG,- KOREA, KINGLAI, APTECH. DKLOK etc.	Follow tender specification; See general-comment – 2
	Multi gas type mass flow controller	Need the list of Gases used for MFC	See annexure - 1
	Expected flow rate up to 300cc/minutes	Range of MFC to be specified	0-300cc/min
	Ultra-high accuracy in flow rate	What is the accuracy and do u need Digital or Analog	Dual Interface, with 0.5-to-1% accuracy
	Calibration should be done as per requirement at the site.	Gases needed and control equipment's for it	Gases will be decided during installation. Bidder to provide equipment's for site calibration.

	Qualified Brand: Fujikin, Bronkhrst, MKS	Since global tender , very specific makes are allowed , Additional other makes as per international standards which are used in Semiconductors Fabs or R&D to be approved examples - HGS Korea, Horiba, Alicat , Hitachi	See general-comment – 2
	All flammable gases including H2 and O2 should be kept in gas cabinet with appropriate purge block panel arrangement, detectors and exhausts.	Please specify cabinet standards internation Semi ? Amd Also what types Manual /Semi or Fully Automatic	We require a single cylinder manifold inside the cabinet with emergency shut-off & 3-way Purge block. See general-comment – 1 and 2
	All corrosive gases including CL2 should be kept in gas cabinet with appropriate purge block panel arrangement, detectors and exhausts.	Please specify cabinet standards internation Semi ? Amd Also what types Manual /Semi or Fully Automatic	We require a 7 valve gas panel inside the cabinet with emergency shut-off & 3-way Purge block; See general-comment – 1 and See general-comment – 2
	Il gas cabinets should have lock alarm for each gas, extraction should be done via scrubber: capable of auto-shutting via pneumatic supply valves if alarms is activated. All key features of cabinet dedicated to gas distribution system should be provided in detail.	More Details on Scrubber Required	Check Annexure – 1
	Provide appropriate centrifugal exhaust and simple exhaust system for all gas cabinet, tool extraction and pump exhaust via scrubber.		
	At point of use a separate valve manifold box with extraction should be provided for chlorine and hydrogen gases;the exhausts should be connected through respective gas cabinets.	Qty of Stick is required and Connections VCR Type?	Check Annexure – 1

	Gas detection system for each corrosive, toxic and flammable gas must be installed in appropriate places.	Specify the Qty for proper costing and FUM Matrix Required	Check Annexure – 1
	•Alarms must be housed in a suitable enclosure and must sample all the welding joints.	Specify the Qty for proper costing and FUM Matrix Required	Check Annexure – 1
	•Hydrocarbon sensors and monitors should be provided	Specify the Qty for proper costing and FUM Matrix Required	Check Annexure – 1
	•CL2 sensors and monitors should be provided	Specify the Qty for proper costing and FUM Matrix Required	Check Annexure – 1
	•SF6 sensors and monitors should be provided	Specify the Qty for proper costing and FUM Matrix Required	Check Annexure – 1
	•O2 level monitors should be provided in different places	Specify the Qty for proper costing and FUM Matrix Required	Check Annexure – 1
	•Smoke Detectors should be installed in the gas bunker and other places wherever needed	Specify the Qty for proper costing and FUM Matrix Required	Check Annexure – 1
	Qualified vender: Honeywell, Bionics, Draeger	Since global tender , very specific makes are allowed , Additional other makes as per international standards which are used in Semiconductors Fabs or R&D to be approved examples - Allan Bradley , Accudevice, Reking Keike, Crowcon	Comply General Comment – 2
	Mask with compatidle cartidge for above gases	Gases for which Mask is used	CL2 & SF6.
	Fuel Bodysuit	Application	Comply our requirement
	Nitrogen Gun	Qty of Guns	2
	A mobile Gas leak detector	Gases for which you want , Multi or single for each	Multi gas
	Vendor should quote for a complete solution for a generator, compressor and receiver along with compatible accessories.	Pressure and Flow needed	Please read the NIT document, it is mentioned in A.1
	A Nitrogen generator capable of 5N or better Nitrogen at 5LPM or better should be	Possible to offer higher flow considering future	You may, however, the evaluation point is set to the mentioned specs

	installed along with an oil free compressor.		
	Provide a 200L Nitrogen storage tank made out of SS-314 or SS-136	Capacity can be bigger	May be, however, the evaluation point is set to the mentioned specs
	The bidder may tie up with nitrogen generator company or vendor to provide the intricated quotation.	We manufacturer in house? Why we should tie-up its can be outsourced	Not a mandatory condition, please read it carefully.
	Nitrogen must be supplier to tools and coaxial purge lines.	Checking the technical Specifications	Comply our specs
	Qualified Brands For Air compressor: ingsoll Rand , Kaeser, Atlascapco	Since global tender , very specific makes are allowed , Additional other makes as per international standards which are used in Semiconductors Fabs or R&D to be approved examples - CP and Molesleives, MVS	Comply our specs; see General Comment – 2
	An oil free air compressor	CFM required	See Annexure - 1
	Qualified Brands For Air compressor: ingsoll Rand , Kaeser,Atlascapco	Since global tender , very specific makes are allowed , Additional other makes as per international standards which are used in Semiconductors Fabs or R&D to be approved examples - CP and Molesleives, MVS	Comply our specs; see General Comment – 2
	Gas cylinders: Vendor should provide ultra pure gases as per following specifications	Please consider these project along with gases and installation due avoid any failures in QC and having good coordination by single vendor	Must Comply our conditions. The evaluations will be done separately as mentioned in our tender.
	Gas and supplied with manufacturer test certificate and certificate of approval from chief controller of Explosive, Nagpur (or) equivalent.	Please consider these project along with gases and installation due avoid any failures in QC and having good cordination by single vendor	Must Comply our conditions. The evaluations will be done separately as mentioned in our tender.
	New, high pressure seamless carbon dioxide gas cylinder of 47 liter water capacity , complete with neck ring and valve , painted as specified under gas cylinder act 2004 and	Indian Cylinders applied for inert gases	Comply our specs and conditions; see General Comment – 2

	filled with 30kg.		
	New high pressure samoleless hydrogen gas cylinder of 47 liter water capacity, complete with neck ring and valve , painted and specified under gas cylinder act 2004. and filled with 7.0 Cu.meter of 99.999% pure hydrogen gas.	Indian Cylinders applied for inert gases	Comply our specs and conditions; see General Comment – 2
	New,high pressure seamleas nitrogen gas cylinder of 47 liter water capacity , complete with neck ring and valve ,paited as specified under gas cylinder act 2004 and filled with 7.0 Cu.meter of 99.999% pure nitrogen gas.	Indian Cylinders applied for inert gases	Comply our specs and conditions; see General Comment – 2
	A new xenon gas cylinder with 99.999% purity of about 10 liter or more of gas with appropriate valve.	Content of gases can be specified by customers , in Kgs and M3,	Vendor may quote in total weight in Kg and M3 must comply with the tender document for volume for comparison. See the condition in annexure
	A new Helium gas cylinder with 99.999% purity of 40 liter of gas or nearest available gas with appropriate valve.	Imported cylinder 40 Ltrs , Indian arr 47 or 50 Ltrs	Vendor may quote in total weight in Kg and M3 must comply with the tender document for volume for comparison. See the condition in annexure
	A new neon gas cylinder with 99.999% purity of 50 liter of gas nearest available gas with appropriate valve.	Content of gases can be specified by customers , in Kgs and M3,	Vendor may quote in total weight in Kg and M3 must comply with the tender document for volume for comparison. See the condition in annexure
	Two orgen gas cylinder with 99.999% putity of 40 liter of gas nearest available gas with appropriate valve.	Content of gases can be specified by customers , in Kgs and M3,	Vendor may quote in total weight in Kg and M3 must comply with the tender document for volume for comparison. See the condition in annexure
	A new krypton gas cylinder with 99.999% putity of 10 liter of gas nearest available gas volume with appropriate valve.	Content of gases can be specified by customers , in Kgs and M3,	Vendor may quote in total weight in Kg and M3 must comply with the tender document for volume for comparison. See the condition in annexure

A new CF4 gas cylinder with 99.999% purity of 50 liter of gas or nearest available gas with appropriate valve.	Content of gases can be specified by customers , in Kgs and M3,	Vendor may quote in total weight in Kg and M3 must comply with the tender document for volume for comparison. See the condition in annexure
A new CF6gas cylinder with 99.999% purity of 50 liter of gas or nearest available gas with appropriate valve.	Content of gases can be specified by customers , in Kgs and M3,	Vendor may quote in total weight in Kg and M3 must comply with the tender document for volume for comparison. See the condition in annexure
A new O2 gas cylinder with 99.999% purity of 50-liter of gas or nearest available gas with appropriate valve.	Content of gases can be specified by customers , in Kgs and M3,	Vendor may quote in total weight in Kg and M3 must comply with the tender document for volume for comparison. See the condition in annexure
A new CL2 gas cylinder with 99.999% purity of 10 liter of gas or nearest available gas with appropriate valve.	Content of gases can be specified by customers , in Kgs and M3,	Vendor may quote in total weight in Kg and M3 must comply with the tender document for volume for comparison. See the condition in annexure
A new CH4 gas cylinder with 99.999% purity of 45 liter of gas or nearest available gas with appropriate valve.	Content of gases can be specified by customers , in Kgs and M3,	Vendor may quote in total weight in Kg and M3 must comply with the tender document for volume for comparison. See the condition in annexure
A new C2H2F4 gas cylinder with 99.999% purity of 45 liter of gas or nearest available gas with appropriate valve.	Content of gases can be specified by customers , in Kgs and M3,	Vendor may quote in total weight in Kg and M3 must comply with the tender document for volume for comparison. See the condition in annexure
A new CF4 gas cylinder with 99.999% purity of 50 liter of gas or nearest available gas with appropriate valve.	Content of gases can be specified by customers , in Kgs and M3,	Vendor may quote in total weight in Kg and M3 must comply with the tender document for volume for comparison. See the condition in annexure
A new C4H10 gas cylinder with 99.999% purity of 45 liter of gas or nearest available gas with appropriate valve.	Content of gases can be specified by customers , in Kgs and M3,	Vendor may quote in total weight in Kg and M3 must comply with the tender document for volume for comparison. See the condition in annexure
A new C3H2F4 gas cylinder with 99.999% purity of 45 liter of gas or nearest available	Content of gases can be specified by customers , in Kgs and M3,	Vendor may quote in total weight in Kg and M3 must comply with the tender document

	gas with appropriate valve.		for volume for comparison. See the condition in annexure
	A new C2H6 gas cylinder with 99.999% purity of 45 liter of gas or nearest available gas with appropriate valve.	Content of gases can be specified by customers , in Kgs and M3,	Vendor may quote in total weight in Kg and M3 must comply with the tender document for volume for comparison. See the condition in annexure
	note: The order can be divided in to multiple purchase orders depending on availbilty from each source. Thus, vender can quote for any subset of gases available with them. Vender should rovide seprate quotations for cylinder with 10-liter water capacity (or nearest available capacity) and 50 liter water capacity (or nearest available capacity) gases. technical commiitted will decided which one to purchase during the ordering time.	If 10 Ltrs we need content in M3 or Kgs	Vendor may quote in total weight in Kg and M3 must comply with the tender document for volume for comparison. See the condition in annexure
	Qualified vendors : Linde, Praxair, Mathesongas,Inox Air product/Air products	Many other makes like, AGEM, AIRGAS , UPG etc are available since all buy from out of india	Comply with Tender specification; see general comment - 2
	D.General term and conditions		
	The bidder should provide authorization and proof of trainning from OEM for major gas distribution hardware like gas panel, cabinets and regulators. In the absence of such authorization certificated , bid with be disqualified.	Our Indian Partners can be allowed to support for Guarantee and warrantee under agreement between both of them	Vendor must comply our conditions
	Above specifications are meant to meet the general requirements; Any minor technical changes providing the same solution as per our requirment can be accepted or rejected by technical committee.		

	The equipment should carry three year on site comprehensive warranty. Warranty period will start from from the date of successful handling over all the item at site.	Our Indian Partners can be allowed to support for Gurantee and warantee under agreement between both of them	Vendor must comply our conditions
	comprehensive warranty includes spare parts and detector sparts and any consumables excluding gases. During the warranty period, regular servicing/maintenance undertaken free of charge, including replacement of defective parts/travel cost, etc. subsequently, servicing/maintenance should be undertaken by the authorized agency of the manufacturer/supplier as per the annual maintenance contract conditions.	Our Indian Partners can be allowed to support for Gurantee and warantee under agreement between both of them	Vendor must comply our specs
	In case of short supply or wrong supply of items , its parts or accessorie or supply of items in damaged conditions,it is the responseibility of the bidder to arrange for the supply of the required items in working condition as per the purchase order, within a reasonable item.any addition expenditure , whatsover,for the above will be borne by the bidder only.		
	All the items to be supplied should be new, of good quality and standard and as per the technical specifications mentioned in technical bid document.	BOQ of products should be quantified for better comparison	This is a complete project, not an order of raw materials; estimation should be done by vendors as per our requirements.
	The vendor will provide operational manuals, OEM documents of peripherals, set of diagnostics to test the sub-systems etc.along with the systems.		
	The bidder shall also maintion the probeble life expectancy of the quipment under normal conditions of operation should be		

	started whatever applicable.		
	Terms for service contact (comprehensive or non-comprehensive) after the expiry of warranty period are to be included.		
	Parties should specify the make and model of each item along with all other details.	ADDITIONAL Makes for qualifications	Already 3-5 makes are been provided in each segment. Follow tender specification; see general comment - 2
	Tender not conforming to any all the about terms and condition will be rejected in incomplete tenders are liable to be rejected.	Any specific terms for International bidders	They must agree our all condition as application to all.
	All vendors participating in tender are expected to give a presentation of their proposal. If the committee finds they can do safe job they will be qualified technically.	Foreign bidders will be allowed since it's a global tender?	Provided service and emergency response units are available in India for quick responses. They must agree our all condition as application to all.
	End-user will also collect the feedback from various labs to qualify the vendor, therefore bidder must provide reference (email, telephone etc.) from the previous installation in national labs, IITs, IISERs and any other research institutions.	If its international Companies, how can we get connected or email can be applicable	That is up to vendor, but bidder must comply our specs and conditions
	Any queries should be addressed during pre-bid meeting; no question/queries will be entertained after pre-bid meeting. Interested vendor may join the meeting.	Extension of bid submission to be considered	We have extended.
	After pre-bidding, we will have technical presentation of the offered solution for qualifying the bids, we may ask for a written answer from technical person from the vendors, will be used for qualifying/disqualifying vendors.	For Presentation Preparation we may need 2 weeks minimum on the same	Date will be available and must be complied by bidder.
	Vendor should submit separate quotes for	Can our principle can bid directly in USD	The bidder can bid directly in USD and

each group of items, however, the quotations should be complete as per specs and requirements within the group unless otherwise it is mentioned.	in that case EMD and Tender Fees Applicable or not	EMD/Tender fees must be paid by local agent/distributor/vendor/bidder. No Exemption for the tender fee and EMD to the foreign bidder.
--	--	---

	Please quantify the BOQ such that all vendors will be compared at one platform.	This is a complete project and we have specified our requirements and a diagram. Bidder must comply our minimum requirements and evolved their own BoQ.
	Considering Safety and Quality. Kindly mentioned that al*1 Gas cabinet and Gas Panels must be Semi2 approved with 3rd part Semi2 test certificate*. This will not allow local suppliers to quote local material.	No suggestion can be accepted to disallow someone. Comply our condition; see General Comment – 1;
	*Requesting you to approve other makes in gas *cabinet,* *panels and regulators, valves and fittings (Norcimbus, Air Gas, Acuu Device, CERES, AGEM, Gas ARC, Tescom, AP Tech, SVT,TKF)* As you see they are very renowned and good brands considered in Semiconductor Industry, They are already in use at: *INDIA: All Photovoltaics industry, SCL â€“ Mohali, ISRO, Led Fab, IIT, IIST, SSPL etc.* *International: Taiwan Semiconductor, Intel, LG, Samsung, UMC, Toshiba, Samsung, Canon, Hitachi etc*.	Already 3-5 makes are been provided in each segments Follow tender specification; see General Comment – 1 and 2
	Gas Cabinets are manual/ Semi automatic/ Automatic type?	We require a 7 valves in gas panel inside the cabinet with emergency shut-off & 3-way Purge block..
	For *Gas kindly mentioned the qty of Gas in KG/ m3* for each cylinder. Thus all vendors will be at same level. While few vendors will give less qty of gas and thus try to quote at less price.	We have mentioned water equivalent of standard cylinders. This is up to bidder to evaluate correctly and attached the detailed chart. See annexure - 2
	Requesting you to add other *vendors/Brands *in *gases like AGEM, UPG as* they are also leading suppliers in semiconductor industry. They are approved in leading semiconductor fabâ€™s in the* world TSMC, Genix, Maxchip, promos, UMC, TSC, SMIC.* In India like* ISRO, IITâ€™s, SSPL etc.* Thus you will get all mentioned *gases within very short span of time like less than 12 weeks.*	Comply both General Comment – 1 and General Comment - 2

	How MFCs will be controlled? MFCs are Digital/ analogue?	Dual Interface, with 0.5-1% accuracy
	How much qty of gas leak detectors, kindly quantify. Also, allow other international brands to bid the project.	Quantities are mentioned in annexure – 2; go through General Comment - 2
	. As we got few approved vendors for scrubbers. Is it still necessary for tie up?	Comply our requirement
	Please provide the scope matrix/ Field utility matrix for all gases. Flow rate and pressure rating for N2 generator and Compressor.	See attached drawing & Annexure -2
	Request you to reconsider and verify the flowrate for N2 generator as they seems to be very small. Kindly add few more vendors or equivalent vendors for larger capacity of 5N grade N2 plants.	This is as per our minimum requirement; it is bidders wish to bid larger system, but tender evaluation will be done on the basis of the minimum requirement.
	N2 generator and compressor can be one system. Thus you can save cost.	No, they must be separate systems
	Also, requesting you to extend the date for Tender for another 15 days after receiving reply for all above mentioned queries. If other vendor/ brands / equivalent makes are allowed then we would be in position to bid, as all qualified brands/ vendors mentioned in tender are true competitors and will not be quoting us directly/ indirectly.	We have specified enough number of brands and makes as per our expertise and experiences to have a uniform evaluation and comparison. Bidder must comply our specs and conditions; see general comment – 2;

Sl. No	Clause	Description	Queries by UHP Tech	Reply
1	E-tender Notice	EMD	UHP is MSME registered under NSIC, hence typically in most of the government tenders EMD and Tender fee is exempted. Kindly requested to confirm exemption of EMD and tender fee on this tender	Yes, provided company is having valid MSME/NSIC certificates.
2	Instructions/Point No -5	Custom duty exemption	UHP proposes to avail custom duty exemption on imported goods through HSS (High Sea sales) Agreement, kindly confirm.	HSS (High Sea sales) is not acceptable.

3	Instructions /Point no-7	Delivery period	Please share the expected delivery period by IISER, UHP proposes delivery period of 16-20 Weeks for supply and 6-8 weeks for installation.	~20 weeks
4	A .2 of “ specification of gas distribution system” page No-1	All lines must be anchored to a tray hook to the roof	UHP proposes to use GI unistrut for tube laying along with plastic insulator and SS clamps to avoid galvanic corrosion and for better aesthetics. Kindly confirm.	Only SS and Ceramics Insulators are allowed. Any non-flammable plastic - provided – the rating and spec list are provided by appropriate produces. Bidder must sign a general agreement, as they will remain responsible for any flame enhancement by such plastics in case of fire.
5	A.2 of “specification of gas distribution system” page No-1	All feed – through holes must be sealed properly	Any civil activity shall be in scope of customer. Holes required for gas lines on clean room panels shall be done and properly sealed with silicon, rubber with SS plate by UHP Tech. However any disturbance in clean room parameters shall not be responsibility of UHP Tech.	Civil work related to this installation is the scope of the vendor. Any damage to properties due to mishandling and installation procedure are liability to the vendor.
6	A.2 of “ specification of gas distribution system” page No-1	Compressed Nitrogen should have a common regulator for pressure control, whereas compressed air line should have multiple regulators at different places (6 points) along with a centralized regulator.	Please clarify if Gauges and isolation valves are required along with regulator. If yes, please mention quantities of gauges and isolation valves.	See Annexures
7	A.3 of “Specifications of gas distribution system”	X-Ray verification for all joints should be done and report should be provided.	Generally X-ray verification is be done for 5% of total no of welds and all joints (orbitally welded) are tested by pressure decay test by Nitrogen followed by leak test by Helium individually ,please clarify .	All joints are required to be x-ray verified, comply our requirements. Comply our specs

8	A4 of “primary pressure control regulator Panel”	All process gases should come with single cylinder along with primary pressure control panel with NPT/Compression ends.	For high purity, Corrosive, Reactive, Toxic, Flammable gases panel comes along with Face sealed fittings (VCR) for better leak integrity. Kindly confirm.	Cl2 needs VCR with pigtail as specified in the specs
9	A4 of “primary pressure control regulator Panel”	Qualified Brands for regulator: AES, Spectron, Air Liquid	AES and Air Liquid doesn’t manufacture regulator. It leads to single approved make hence UHP proposes following equivalent or better makes. 1. Tescom 2. APTEch 3. Rotarex.	The requested brands are for the entire assembly of the panel & not individual regulators. Although we have clarified by mentioning approved makes for regulators and panels separately. Refer the clarifications.
10	A4 of “primary pressure control regulator Panel”	Panel must have inbuilt sintered filter made of compatible materials.	Please specify the size of filter	~0.5 micron (minimum)
11	A4 of “primary pressure control regulator Panel”	Panel details	Please specify number valves in Regulator panel for each gas.	Minimum 7-valve panel with a provision for future conversion into fully automatic panel.
12	A5 of “Valves, clamps, diaphragm and related accessories “	Filter at the process gas inlet valve	Please specify the size of filter	~0.5 micron (minimum)
13	A5 of “Valves, clamps, diaphragm and related accessories “	Should be provided with 316L stainless steel bodies downstream of seat NPT/Compression fittings.	For high purity, Reactive, Toxic, Flammable gases panel comes along with Face sealed fittings (VCR) for better leak integrity, kindly confirm.	Answer in 8
14	A5 of	Manual shutoff valve should	For Toxic and flammable gases it is advised to	Please read carefully, this was

	“Valves, clamps, diaphragm and related accessories “	be provided in utilities areas (two: one in cleanroom and other one in experimental-area), and inside gas-room (one).	use VMB’s (Valve manifold boxes) with enclosures to restrict Hazard due to leakage from valve. Please clarify.	mentioned as enclose in the specs. Exhausts of VMBs must connect to gas cabinet, which will be eventually tested for leaks and exhausted.
15	A5 of “Valves, clamps, diaphragm and related accessories “	Qualified Brands for Electro Pneumatic Actuated Valve	UHP proposes following makes 1. APTech 2. Rotarex.	Already 3-5 makes are been provided in each segment and hence we don’t find a reason to add. Follow latest tender specification. See General Comment – 2
16	A5 of “Valves, clamps, diaphragm and related accessories “	Qualified Brands for Electro Pneumatic Actuated Valve	UHP proposes following makes APTech Rotarex	Already 3-5 makes are been provided in each segment and hence we don’t find a reason to add. Follow latest tender specification. Comply General Comment – 2
17	A6 of “Mass Flow Controller “(MFCs)	Mass Flow Controller (MFCs)	Please specify end connection of MFC’s	Swage-lock type, MFCs are multi-gas
18	A7 of “Gas cabinet and housing of cylinder “	All gas cabinets should have leak alarm for each gas, extraction should be done via scrubber: capable of auto-shutting via pneumatic supply valves if any alarm is activated. All key features of cabinet dedicated to gas Distribution system should be provided in detail.	Please specify the scope of scrubber Please specify if Sprinkler along with piping and isolation valve is require Thickness of enclosure MOC of enclosure.	Water Sprinkler is needed in all flammable gases, not in Cl2 Thickness: ~3mm more thickness or equivalent Appropriately Powered coated MS

		Provide appropriate centrifugal exhaust and simple exhaust system for all gas cabinet, tool extraction and pump exhaust via scrubber.		
19	A7 of “Gas cabinet and housing of cylinder “		To design appropriate exhaust system outlet exhaust flow rates of Tools, Pumps along with Number of connections and end connections are required, please clarify.	Total flow rate is mentioned in the tender document
20	A7 of “Gas cabinet and housing of cylinder “	At point of use a separate valve manifold box with extraction should be provided for chlorine and hydrogen gases; the exhausts should be connected through respective cabinets.	Please specify detailed technical specification of VMB i.e. 1. Number of sticks (stick= Regulator+Guage + Isolation Valve etc.) 2. Gas Leak detectors , 3. ROR sensors , 4. Sprinklers etc.	See Annexures and clarification sections
21	A7 of “Gas cabinet and housing of cylinder “	Qualified brand	UHP proposes the qualified brand KAS.	No, See general comment - 2
22	A8 of “Gas Monitoring and alarm System”	Gas Monitoring and alarm System	Please specify Number of gas leak sensors.	See Annexures
23	A9 “Personal Protective Equipment	A mobile Gas leak detector	Please specify Number of gas leak sensors.	See Annexures

	(PPE) and Accessories “			
24	C	Gas Cylinders –Qualified vendors	UHP Proposes Bhuruka gases.	Already 3-5 makes are been provided in each segment. See general comment - 2
25			UHP requests for FUM(Facility Utility Matrix) & P&ID	See Annexure - 1
26			UHP request for Site visit if possible.	Yes

Si. N O	Tender reference		Tender Queries	CCD consideration	Client's conformation	Remarks
	Page No	Referen ce No				
1	1	A.2 (point no-1)	16 types of gases mentioned, Page No-4, C.1 points 17 types of cylinder	16 gas services for Gas tubing installation and 17 type of gases for gas cylinder supply	Please see corrected numbers in attached document	Xenon cylinder is additionally added in gas cylinder supply
2	1	A.2 (point no-1)	N2 gas manifold required or Not??	1/4" Gas service pipe line considered for pure N2 & 1" Gas service piping considered for General N2	N2 from cylinder with 6N and service line is a separate line	99.9999% N2 gas cylinder supply, So we considered as a PN2
3	1	A.2 (point no-3)	5- NO of Spare pipe line mentioned as 40 -50 feet (from gas bank to utility area). All process gases point of use location not clear. Individual P& ID required for all gases including CA & GN2. Process gas pipe sizes not mentioned	From gasbank to utility area 100 feet (30 meter) for future use spare line. 1/4" size tube considered for all process gas.	See annexures	CCD considered placing the Co-axial tube gas services cabinet in room entry. Spare line routing from near the empty cylinder stand.

4	1	A.3 (point no-3)	X- Ray test mentioned for all joints, what about co-axial tube sleeve joint	RT considered only for co-axial inner process line; pressure leak test considered for sleeve joints.	No required	conformation required
5	2	A.3 (Last point)	Co-axial tube considered for ALL flammable and toxic gases	CL2,SF6,H2,CH4,C2H6 & C4H10	Yes	conformation required
6	2	A.4 (5th point)	All process gases regulator NPT/compression end	O2,CL2,SF6,H2,CH4,C2H6 & C4H10 gases control panel will come with Face seal fittings and all other gases control panel will come with NPT/compression fittings	Yes	conformation required
7	2	A.4 (11th point)	3-way purgeblock requirement mentioned for all flammable and toxic gases	CL2,SF6,H2,CH4,C2H6,O2 & C4H10 gas panel will come along with 3-way purge block	yes	conformation required
8	2	A.5 (5th point)	Auto shutoff valve requirement for all services except N2.	Common SOV will control all gas service pneumatic actuation valve. It will shutoff in emergency alarm.	Yes	conformation required
9	3	A.6	Multi gas MFC. Process location to be conform.		See annexures	conformation required
10	3	A.7	gas cabinet requirement mentioned for all flammable and toxic gases	O2,CL2,SF6,H2,CH4,C2H6 & C4H10 gases will come inside gas cabinet.	Yes, See annexures	conformation required
11	3	A.5 (3rd point)	Scrubber capacity and scope to be conform, Equipment chamber exhaust not mentioned	Exhaust blower only considered & waiting for Scrubber requirement conformation	See annexures	conformation required

12	3	A.5 (last point)	point of use Valve manifold box requirement only for H2 & Cl2. Details not mentioned about unility area entry panel	Common entry panel (including regulator and PG) for all services at utility area. Point of use valve only considered inside clean room & experimental area.	See annexure	conformation required
13	3	A.8 (last point)	Smoke detector or ROR sensor to be conform. And it's locations		See Annexure - 2	conformation required
14	3	A.8	All gas detectors locations and Qty not mentioned	1-Qty for Gasbank; 1- Qty for experimental qty; 1- Qty for Clean room A	See Annexure - 2	conformation required
15	3	A.9	PPE Requirement Qty to be conform. (i.e. multigas detector Qty and masks.). Fuel bodysuit or full bodysuit.		2 + 4 mask with oxygen or appropriate cartages – see annexure Fuel bodysuit => full bodysuit	conformation required
16			CA & GN2 no of drop point requirement not mentioned.		A See Annexure - 2	conformation required
17			inbetween Gas bank to Utility Area gas Pipe rack scope was not mentioned		It will be provided, but the insulation and maintaining temperature through the area should be taken care by vendors	conformation required